

Dell™ Personal All-In-One Printer A960

Owner's Manual

Look Inside For:

- Ordering Supplies
- Getting Started
- Understanding the Software
- Ink Cartridge Maintenance
- Troubleshooting



Ordering Ink Cartridges and Supplies

Your Dell™ Personal All-In-One Printer A960 comes with software installed to detect the ink levels in the printer. During a print job, a screen appears on your computer to warn you if the ink levels are low. You can order ink online at www.dell.com/supplies or by phone.

USA	877-465-2968 (877-Ink2You)
Canada	877-501-4803
Mexico	001-800-210-7607
Puerto Rico	800-805-7545
UK	0870 907 4574
Ireland	1850 707 407
France	0825387247
Italy	800602705
Spain	902120385
Germany	0800 2873355
Austria	08 20 - 24 05 30 35
Netherlands	020 - 674 4881
Belgium	02.713 1590
Sweden	08 587 705 81
Norway	231622 64
Denmark	3287 5215
Finland	09 2533 1411
Switzerland	0848 801 888

Your printer has been designed to print using the following ink cartridges:

Item:	Part number:
Black ink cartridge	7Y743
Color ink cartridge	7Y745

Notes, Notices, and Cautions



NOTE: A NOTE indicates important information that helps you make better use of your computer.



NOTICE: A NOTICE indicates either potential damage to hardware or loss of data and tells you how to avoid the problem.



CAUTION: A CAUTION indicates a potential for property damage, personal injury, or death.

Information in this document is subject to change without notice.

© 2003 Dell Inc. All rights reserved.

Reproduction in any manner whatsoever without the written permission of Dell Inc. is strictly forbidden.

Trademarks used in this text: *Dell* and *DELL* logo are trademarks of Dell Inc.; *Microsoft* and *Windows* are registered trademarks of Microsoft Corporation.

Other trademarks and trade names may be used in this document to refer to either the entities claiming the marks and names of their products. Dell Inc. disclaims any proprietary interest in trademarks and trade names other than its own.

UNITED STATES GOVERNMENT RESTRICTED RIGHTS

This software and documentation are provided with RESTRICTED RIGHTS. Use, duplication or disclosure by the Government is subject to restrictions as set forth in subparagraph (c)(1)(ii) of the Rights in Technical Data and Computer Software clause at DFARS 252.227-7013 and in applicable FAR provisions: Dell Inc., One Dell Way, Round Rock, Texas, 78682, USA.

Caution: SAFETY INFORMATION

Use the following safety guidelines to help ensure your own personal safety and to help protect your computer and working environment from potential damage.

- Use only the power supply provided with this product or the manufacturer's authorized replacement power supply.
- Connect the power cord to an electrical outlet that is near the product and easily accessible.
- Refer service or repairs, other than those described in the user documentation, to a professional service person.

 **CAUTION: Do not use the fax feature during a lightning storm. Do not set up this product or make any electrical or cabling connections, such as the power supply cord or telephone, during a lightning storm.**

Contents

Notes, Notices, and Cautions	3
Caution: SAFETY INFORMATION	4
1 Getting Started	
Understanding the Printer Parts	10
Accessing Your <i>User's Guide</i>	13
Setting up Your Printer	13
Installing the Operator Panel	14
Using the Operator Panel	15
Operator Panel Menus	17
Understanding the Automatic Paper Type Sensor	23
Loading Paper	25
Print Media Guidelines for the Paper Support	26
Load Your Document on the Scanner Glass	28
2 Using the Printer	
Using the ADF	30
Load Your Document Into the ADF	30
Print Media Guidelines for the ADF	31
Printing	32
Print Photos	32
Copying	33

Copy Photos	34
Scanning	34
Scan Photos	36
Edit Scanned Images	36
Scan Multiple Pages or Images	37
Edit text found in a scanned document using OCR (Optical Character Recognition)	37
Save an Image on Your Computer	38
E-mail a Scanned Image or Document	38
Enlarge or Reduce Images or Documents	39
Faxing	40
Using Dell Printer Fax Tools Fax Software	41
Using Fax Console (Windows XP Only)	43
Access the Fax Setup Utility	44
Send a Fax	46
Receive Faxes	48
Print to Fax	50
Viewing Sent Faxes and Received Faxes	51
View the Status of a Fax	51
Using Special Fax Features	52

3 Understanding the Software

Understanding the Printer Software	56
Using the Dell All-In-One Center	56
Access the Dell All-In-One Center:	56
The All-In-One Main Page	57
Using Print Properties	59
Access Print Properties	59
Print Properties Tabs	59
Using the Dell Printer Solution Center	61
Access the Dell Printer Solution Center	61

Using Dell Picture Studio	62
Access Dell Picture Studio	62
4 Ink Cartridge Maintenance	
Replacing Ink Cartridges	64
Aligning Ink Cartridges	65
Cleaning the Ink Cartridge Nozzles	67
5 Troubleshooting	
Setup Problems	70
General Problems	70
Black and White Copy Quality Is Unsatisfactory	72
Fax Does Not Work	73
Printer Is Not Sending or Receiving Faxes	73
Default Country Was Not Set	74
Document Misfeeds or Jams	77
Error Messages and Flashing Lights	78
Improving Print Quality	80
Clean the Ink Cartridge Nozzles	81
Remove and Reinstall the Software	81
More Troubleshooting Options	82
6 Contacting Dell	
Technical Assistance	84
Automated Order-Status Service	84
Contacting Dell	85

7 Appendix

Limited Warranties and Return Policy	98
Dell Inc.	
Ink and Toner Cartridges Limited Warranties	109
Dell Software License Agreement	111
Regulatory Notices	113

SECTION 1

Getting Started

Understanding the Printer Parts

Accessing Your User's Guide

Setting up Your Printer

Installing the Operator Panel

Using the Operator Panel

Understanding the Automatic Paper Type Sensor

Loading Paper

Understanding the Printer Parts

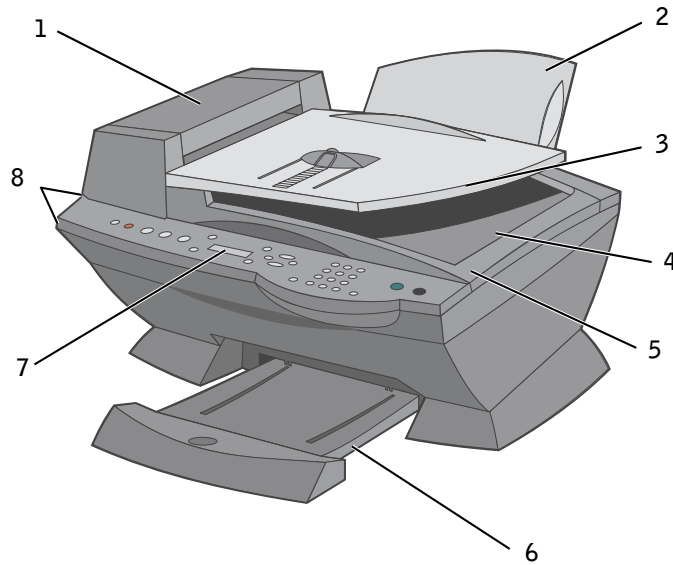

#	Use the:	To:
1	Automatic Document Feeder (ADF)	Scan, copy or fax multiple page documents and/or legal sized documents.
2	Paper support	Load paper into the printer.
3	ADF input tray	Load original documents in the printer. Recommended for scanning, copying, or faxing multiple page documents.
4	ADF exit tray	Pick up your original document after it has gone through the ADF.
5	Top cover	Access the scanner glass: <ul style="list-style-type: none"> • Lift top cover to place or remove items on the scanner glass. • Scanner glass recommended for heavy weight, delicate, or unusually sized originals that can not be fed through the ADF.
6	Paper exit tray	Stack paper as it exits the printer.
7	Display	Check the printer status or view messages, menus, or settings.
8	Operator panel	Operate your printer (attached to a computer or unattached). For more information, see "Using the Operator Panel" on page 15.

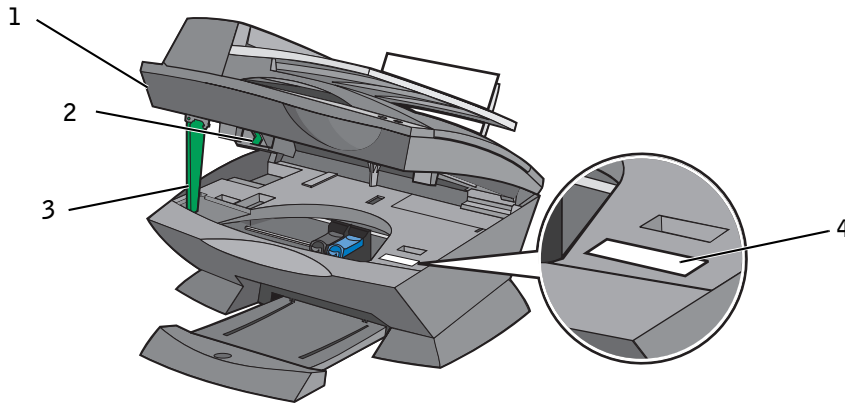

#	Use the:	To:
1	Printer (scanner unit)	<ul style="list-style-type: none"> • Lift to install or change ink cartridges. • Lift to lock or unlock the scanner.
2	Scanner lock	Lock or unlock the scanner. <ul style="list-style-type: none"> • Push the scanner lock <i>away</i> from you for <i>unlocking</i>. • Pull the scanner lock <i>toward</i> you for <i>locking</i>. <p>NOTE: Lock the scanner if you are moving your printer. Unlock the scanner before use.</p>
3	Scanner support	Keep the printer (scanner unit) open when changing ink cartridges or toggling the scanner lock. <p>NOTE: To close the printer (scanner unit) for normal operation: lift the (printer) scanner unit, press the scanner support to the right, then lower the printer (scanner unit) until it rests on the main body of the printer.</p>
4	Express Service Code	<ul style="list-style-type: none"> • Identify your printer when you use support.dell.com or contact technical support. • Enter the Express Service Code to direct your call when contacting technical support. The Express Code is not available in all countries.

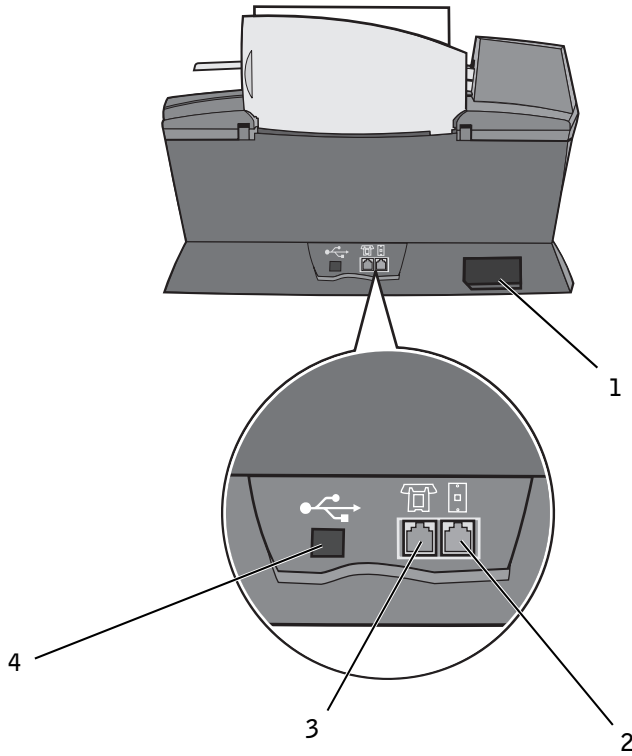

#	Use the:	To:
1	Power supply connector	Supply power to the printer.
2	Wall jack connector	Connect your printer to an active telephone line to send and receive faxes. Your printer must be connected to this telephone line to receive incoming fax calls. NOTE: Do not connect a DSL (digital subscriber line), ISDN (integrated services digital network), or cable modem to the printer.
3	Data/fax modem, answering machine, and telephone connector	Remove the plug to connect additional devices, such as a data/fax modem, telephone, or answering machine to your printer. NOTE: Do not connect additional devices to the wall jack connector, and do not connect a DSL (digital subscriber line), ISDN (integrated services digital network), or cable modem to the printer.
4	USB cable connector	Connect your printer to a computer.

Accessing Your *User's Guide*

Click Start → All Programs (or Programs) → Dell Printers → Dell AIO Printer A960 → View Dell User's Guide.

Setting up Your Printer

 **NOTE:** The Dell Personal All-In-One Printer A960 supports the Windows XP and Windows 2000 operating systems.

Follow the instructions on your printer *Setup Diagram* to install the hardware and software. For setup troubleshooting, see page 70.

You can use the Dell™ AIO Printer A960 to do a variety of things. A few important things to note:

- If your printer is attached to a computer, you can use either the printer operator panel or the printer software to create your projects.
- You *do* need to attach your printer to a computer to scan.
- You *do* need to attach your printer to a computer to print.
- You *do not* need to attach your printer to a computer to make photocopies.
- You *do not* need to attach your printer to a computer to send faxes.

 **NOTE:** The printer must be connected to a telephone line for faxing to function (attached to a computer or unattached).

Installing the Operator Panel

The following instructions apply only if you received an additional language operator panel with your printer.

- 1 Remove the operator panel (if one is installed).

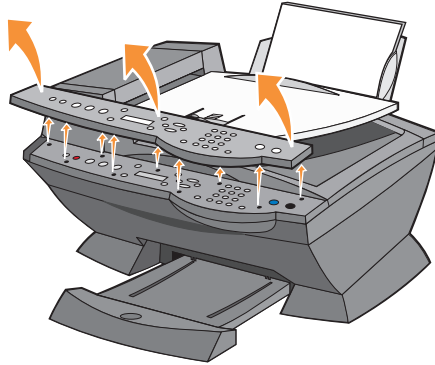

- 2 Choose the correct operator panel for your language.
- 3 Position the clips on the printer, and then press down.

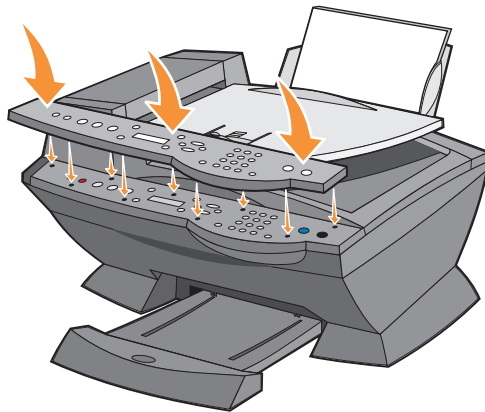

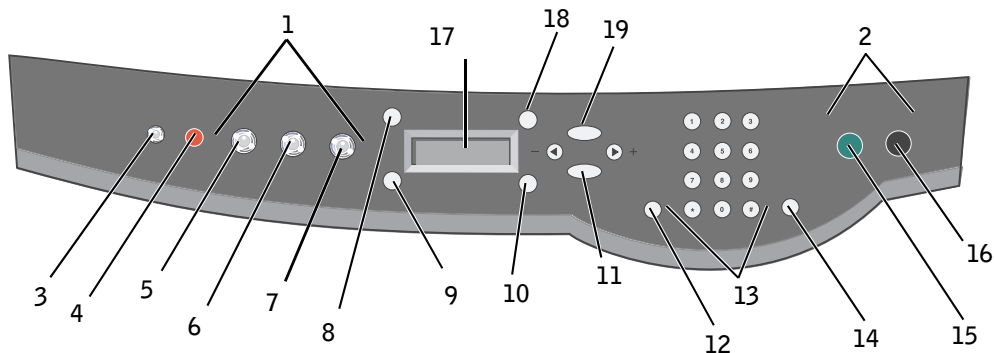

Using the Operator Panel

The operator panel buttons help you scan, copy, fax, and customize documents. When **Power** is lit, the printer is on. You can select a mode from the Mode area, select or change settings using several of the buttons, and initiate a scan, copy, or fax from the Start area on the far right.



Use the:	To:
1 Mode area	Select a Mode (scan, copy, or fax).
2 Start area	Start a color or black and white scan, copy, or fax job.
3 Power	Turn your printer on or off.
4 Stop/Clear (Cancel)	<ul style="list-style-type: none"> Cancel a scan, print, or copy job in progress. Clear a fax number or end a fax transmission and return the display to the fax default. Exit a menu. Clear current settings and return to default settings.
5 Copy	Enter copy mode. NOTE: This button is lit when the printer is in copy mode.
6 Scan	Enter scan mode (possible when the printer is attached to a computer). NOTE: This button is lit when the printer is in scan mode.
7 Fax	Enter fax mode. The printer can receive a fax while in any mode. NOTE: This button is lit when the printer is in fax mode.
8 Number of Copies	Specify a number (1-99) of photocopies.
9 Quality	<ul style="list-style-type: none"> Select from the following copy qualities: Quick, Normal, Better, or Best. Select a fax resolution: Standard, Fine, Superfine, or Ultrafine. Select a scan resolution when the printer is attached to a computer.

	Use the:	To:
10	Lighter/Darker	Lighten or darken a photocopy or fax.
11	Select	Choose the option that appears on the display. NOTE: If you hold down the Select button, the button acts as a paper feed.
12	Speed Dial	Use the speed dial feature while the printer is in fax mode. NOTE: If you press Speed Dial when your printer is in copy or scan mode, the printer automatically switches to fax mode.
13	A keypad number or symbol	<ul style="list-style-type: none"> In fax mode: <ul style="list-style-type: none"> Enter fax numbers. Get through an automated answering system. Select letters when creating a Speed Dial list. Type numbers to enter or edit the date and time shown on the printer display. In copy mode: <ul style="list-style-type: none"> Select the number of photocopies you want to make.
14	Redial/Pause	<ul style="list-style-type: none"> Redial the last number entered when the machine is in fax mode. Insert a three-second pause in the number to be dialed. Enter a pause only when you have already begun entering the number. Press - to insert a pause before number dialed. NOTE: If you press Redial/Pause when your printer is in copy or scan mode, the printer automatically switches to fax mode.
15	Color	Start a color copy, fax, or scan job. NOTE: In the Mode area, make sure the mode you want is lit.
16	Black	Start a black and white copy, fax, or scan job. NOTE: In the Mode area, make sure the mode you want is lit.
17	Display	View printer status, messages, and menus.
18	Reduce/Enlarge	Customize the size of your original document by a percentage, Fit to Page, or to poster size.
19	Options	Scroll through the list of menu headings (see "Operator Panel Menus" on page 17).
	- 	<ul style="list-style-type: none"> Decrease a number on the display. Scroll through a list on the display. Add a space when entering/editing text or numbers on the LCD display, such as speed dial information or fax numbers.
	+ 	<ul style="list-style-type: none"> Increase a number on the display. Scroll through a list on the display. Backspace when entering text or numbers on the LCD display, such as speed dial information or fax numbers.

Operator Panel Menu

See the display for:

- Printer status
- Messages
- Menus

Selecting Operator Panel Menu items

- 1 Press one of the available Mode buttons on the printer operator panel.
- 2 Press **Options** repeatedly until the menu heading you want appears on the display.
- 3 Press + or - to scroll through the available menu items.
- 4 Press **Select** when the menu item you want appears on the display to save the setting.

For more information about using the operator panel, see your *User's Guide*.



NOTE: The option currently selected is noted with an asterisk (*) on the display.

Copy Mode Menu Items

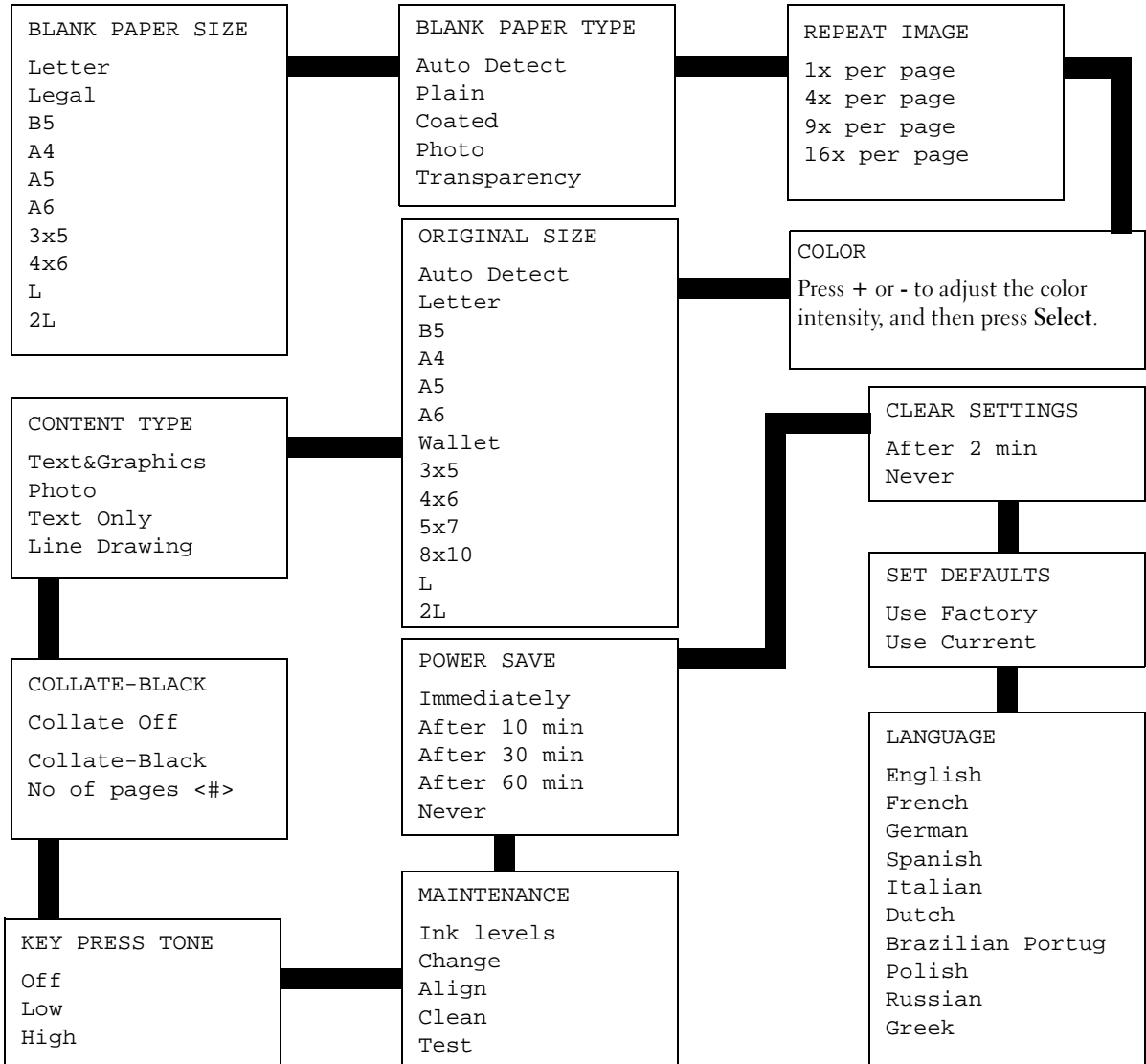

Scan Mode Menu Items

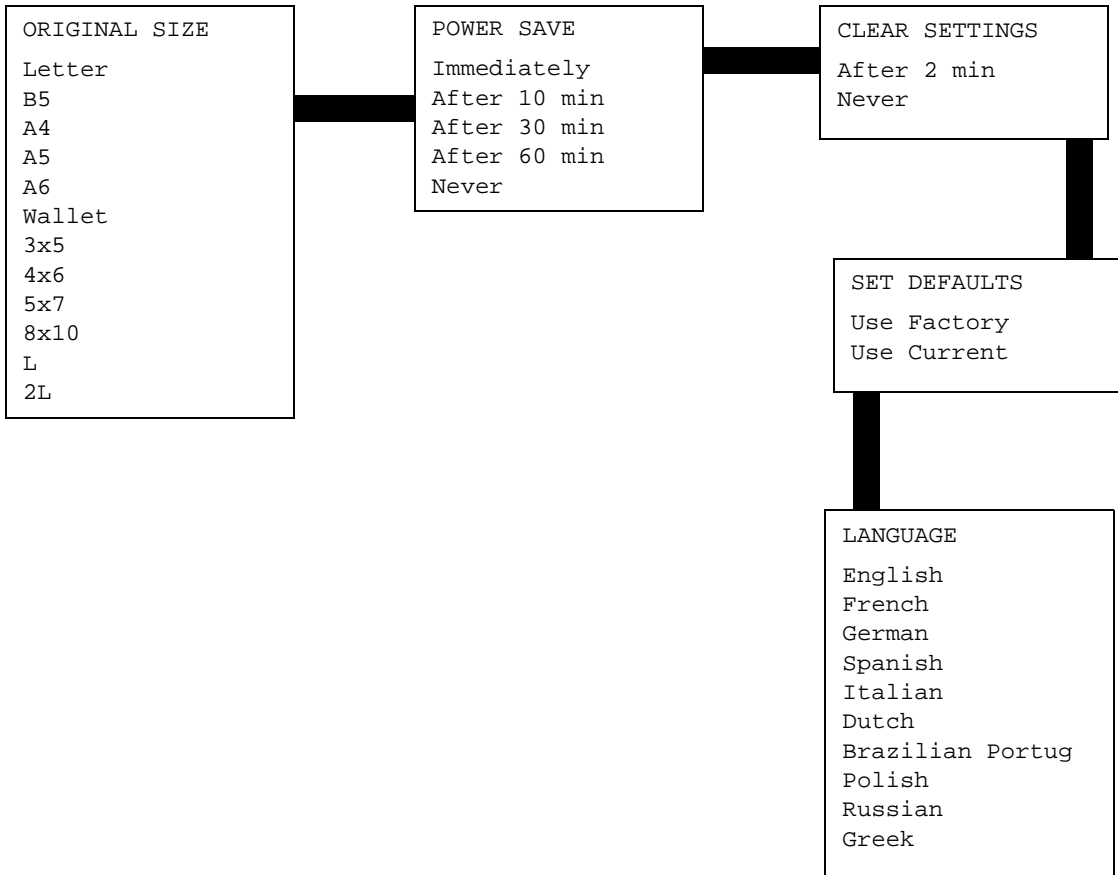

Fax Mode Menu Items

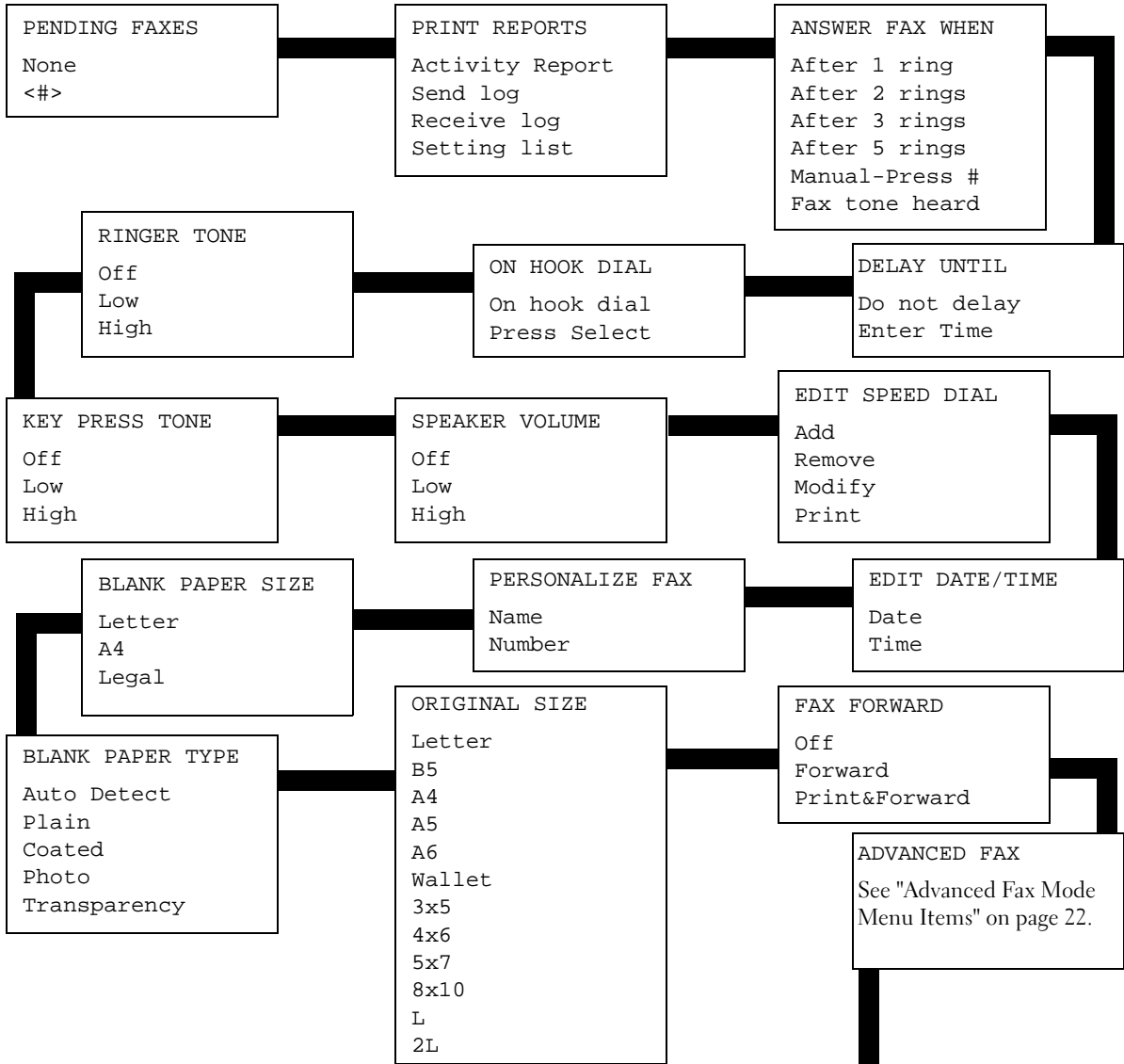

Continued...

Fax Mode Menu Items (continued)

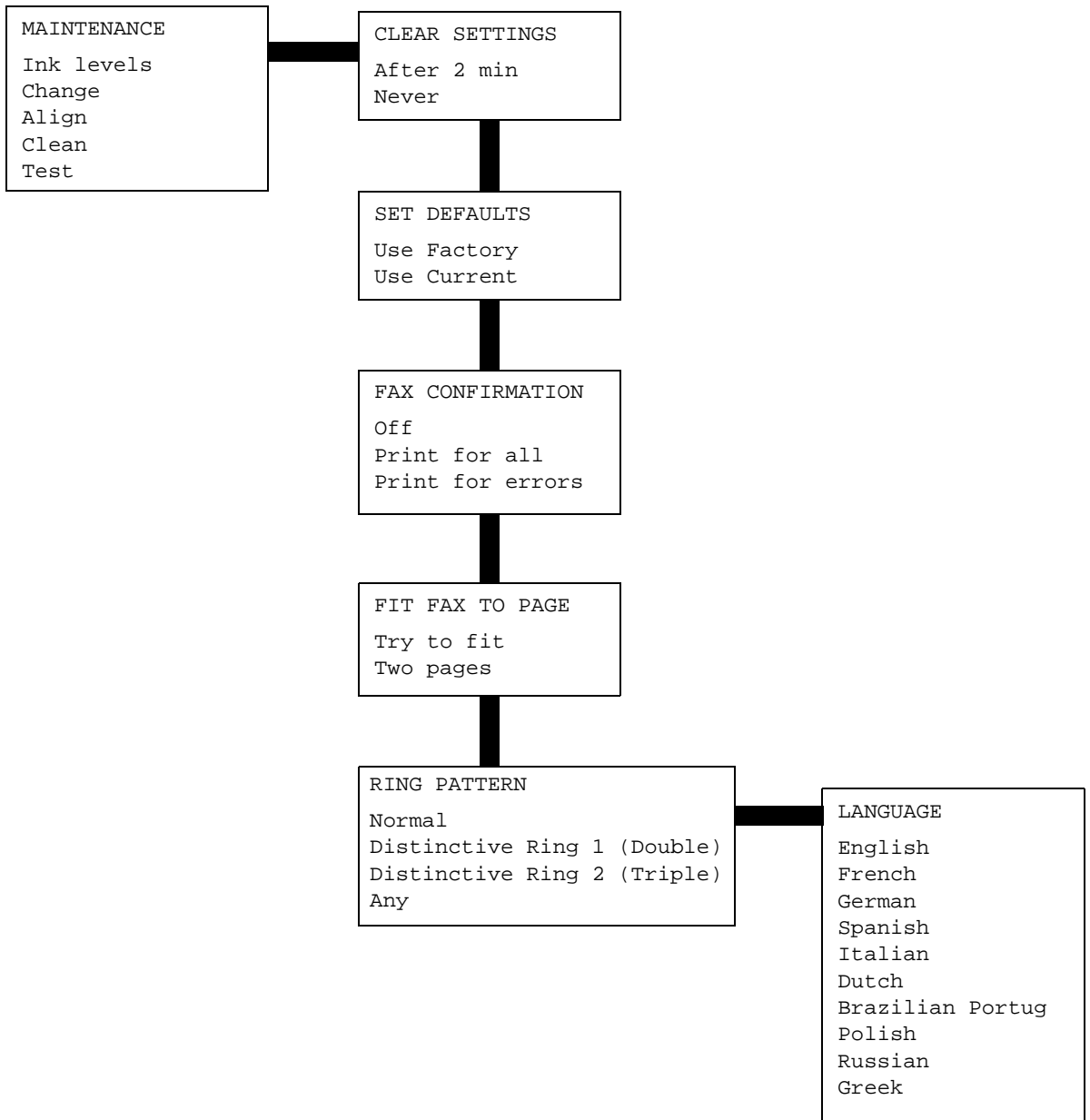

Advanced Fax Mode Menu Items

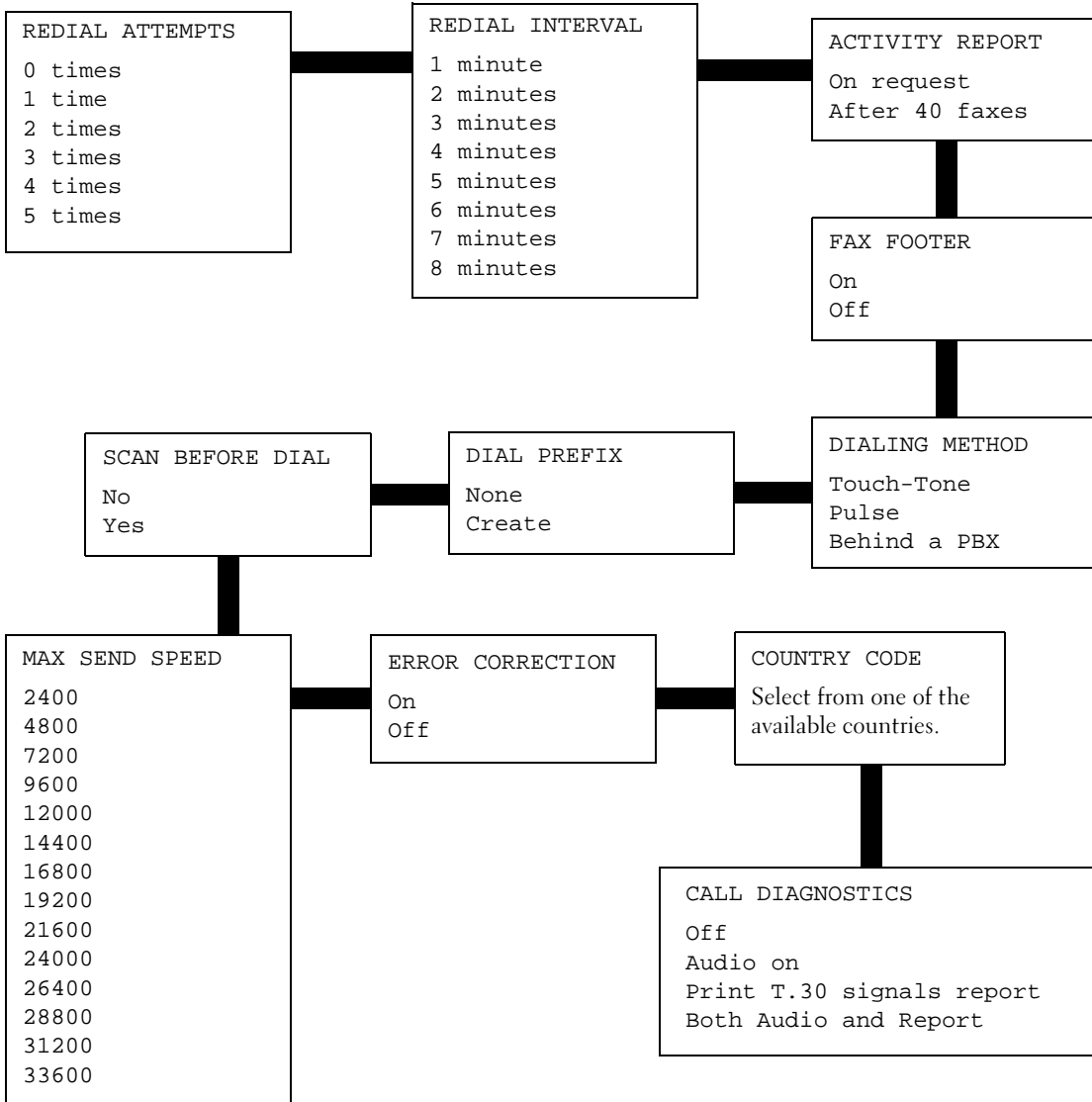

Understanding the Automatic Paper Type Sensor

Your printer has an automatic paper type sensor that detects the following paper types:

- Plain paper.
- Coated paper.
- Glossy/photo paper.
- Transparencies.

If you load one of these paper types, the printer detects the paper type and automatically adjusts the paper type settings.

 **NOTE:** Your printer cannot detect the paper size.

To choose the paper size on which you want to print:

- 1 With your document open, click **File** → **Print**.
- 2 In the Print dialog box, click **Preferences** or **Properties** (depending on your program or operating system).
The Print Properties screen appears.
- 3 From the Paper Setup tab, select the paper size you are using.
- 4 Click **OK**.

The automatic paper type sensor is on unless you turn it off. If you want to turn it off:

- 1 With your document open, click **File** → **Print**.
- 2 In the Print dialog box, click **Preferences** or **Properties** (depending on your operating system).
The Print Properties screen appears.
- 3 Click **Options**.
- 4 Click **Paper Type Sensor Options**.
- 5 Click **Allow the Paper Type Sensor to select paper type** (default) to clear the setting.
- 6 Click **OK**.

To permanently turn it off:

- 1 Click **Start** → **Control Panel** → **Printers and Other Hardware** → **Printers and Faxes** (Windows XP).
Click **Start** → **Settings** → **Printers and Faxes** or **Printers** (Windows 2000).
- 2 Right-click the printer icon.
- 3 Click **Printing Preferences** or **Properties**.
- 4 Click **Options** or the **Printer Settings** tab, and then click **Paper Type Sensor Options**.
- 5 Click the box to clear the setting.
- 6 Click **OK**.
- 7 Click **OK**.



NOTE: To temporarily override the automatic paper type sensor for a particular print job, specify a paper type in the software screen under Specialty Paper.

The basic functions of your printer are the print, copy, scan, and fax functions. First, learn how to load paper into your printer with the following instructions. Continue with "Using the Printer" on page 29 to learn how to print, copy, scan, and fax.

Loading Paper

- 1 Place the paper against the guide on the right-hand side of the paper support.

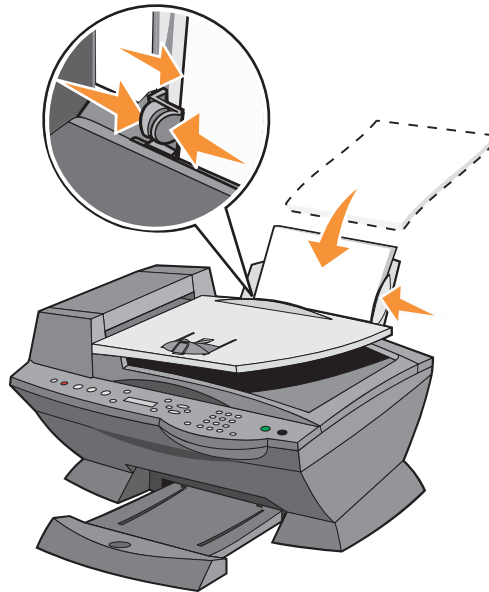

- 2 Squeeze and slide the left-hand paper guide to the left edge of the paper.

 **NOTE:** Do not force paper into the printer. The paper should be flat against the paper support's surface and its right edge should be flush against the right-hand paper guide.

Print Media Guidelines for the Paper Support

Load up to:	Make sure:
100 sheets of plain paper	<ul style="list-style-type: none"> The paper is loaded vertically against the right-hand side of the paper support. The paper guide is against the left edge of the paper. <p>NOTE: Load letterhead paper into the printer upside down with the letterhead facing you.</p>
10 envelopes	<ul style="list-style-type: none"> The print side of the envelopes faces you. The envelopes are loaded vertically against the right-hand side of the paper support. The stamp location is in the upper left corner. The paper guide rests against the left edge of the envelopes. You choose to print the envelopes with Landscape orientation. You select the correct envelope size. <p>Select the next biggest size if the exact envelope size is not listed, and set the left and right margins so that your envelope text will be correctly positioned.</p> <p>NOTE: You can load a single envelope into the paper support without removing plain paper.</p>
10 greeting cards, index cards, postcards, or photo cards	<ul style="list-style-type: none"> The print side of the cards faces you. The cards are loaded vertically against the right-hand side of the paper support. The paper guide rests against the left edge of the cards.
25 sheets of coated, photo, or glossy paper	<ul style="list-style-type: none"> The glossy or coated side of the paper faces you. The paper guide rests against the left edge of the photo paper.
10 transparencies	<ul style="list-style-type: none"> The rough side of the transparencies faces you. The paper guide rests against the left edge of the transparencies. <p>NOTE: You can load a single transparency into the paper support without removing plain paper.</p>

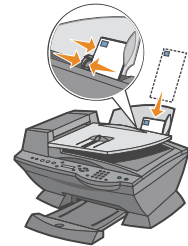

Load up to:	Make sure:
100 sheets of custom size paper	<ul style="list-style-type: none"> • The print side of the paper faces you. • The paper guide rests against the left edge of the paper. • Your paper size fits within these dimensions: <p>Width</p> <ul style="list-style-type: none"> • 76 mm - 216 mm • 3.0 in. - 8.5 in. <p>Length</p> <ul style="list-style-type: none"> • 127 mm - 432 mm • 5.0 in. - 17.0 in.
25 iron-on transfers	<ul style="list-style-type: none"> • You follow the loading instructions on the iron-on transfer packaging. • The blank side of the transfers faces you. • The paper guide is against the left edge of the iron-on transfers.
20 sheets of banner paper	<ul style="list-style-type: none"> • The banner paper is designed for use with inkjet printers. • You adjust the printer properties.

Load Your Document on the Scanner Glass

- 1 Open the top cover.

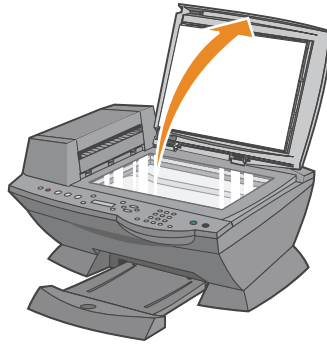

- 2 Place the item you want to copy face down on the scanner glass in the upper left corner.

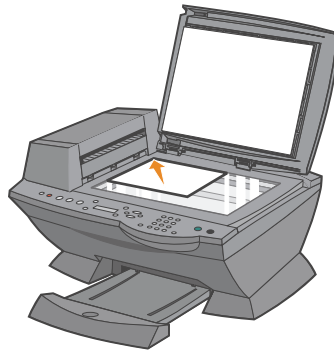

- 3 Close the top cover.

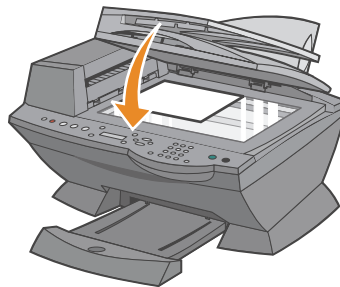

SECTION 2

Using the Printer

Using the ADF

Printing

Copying

Scanning

Faxing

Using the ADF

Load Your Document Into the ADF

NOTICE: Do not load more than 50 sheets into the ADF or allow more than 50 sheets to be fed to the ADF exit tray. The ADF exit tray should be emptied before it exceeds 50 sheets or your original documents may be damaged.

You can load up to 50 sheets of your original document (text side up with page one on top) into the ADF for scanning, copying, and faxing. The ADF is recommended for loading multiple page documents.



Print Media Guidelines for the ADF

Load up to:	Make sure:
50 sheets of letter size paper	<ul style="list-style-type: none">• The document is loaded text side up.• The paper guide is against the edge of the paper.
50 sheets of A4 size paper	<ul style="list-style-type: none">• The document is loaded text side up.• The paper guide is against the edge of the paper.
50 sheets of legal size paper	<ul style="list-style-type: none">• The document is loaded text side up.• The paper guide is against the edge of the paper.
50 sheets of custom size paper	<ul style="list-style-type: none">• The document is loaded text side up.• The paper guide is against the edge of the paper.• Your paper size fits within these dimensions: Width<ul style="list-style-type: none">• 210.0 mm - 215.9 mm• 8.27 in. - 8.5 in.Length<ul style="list-style-type: none">• 279.4 mm - 355.6 mm• 11.0 in. - 14.0 in.
50 sheets of two, three, or four hole pre-punched media	<ul style="list-style-type: none">• The document is loaded text side up.• The paper guide is against the edge of the paper.• Your paper size fits within the dimensions allowable.
50 sheets of edge reinforced three hole copier media	<ul style="list-style-type: none">• The document is loaded text side up.• The paper guide is against the edge of the paper.• Your paper size fits within the dimensions allowable.
50 sheets of preprinted forms and letterhead media	<ul style="list-style-type: none">• The document is loaded text side up.• The paper guide is against the edge of the paper.• Your paper size fits within the dimensions allowable.• You choose a media that absorbs ink well.• You allow the preprinted media to dry thoroughly before use in the ADF.• You do <i>not</i> use media printed with metallic ink particles in the ADF.• You avoid embossed designs.



NOTE: Do *not* load heavy-weight paper, transparencies, postcards, photo cards, or photo paper into the ADF.

Printing

- 1 Make sure your computer and your printer are on.
- 2 Load paper. For help, see page 25.
- 3 With your document open, click **File** → **Print**.
- 4 To change the printer settings, click **Preferences** or **Properties** (depending on the program or operating system).
- 5 On the three tabs along the left side (Quality/Copies, Paper Setup, and Print Layout) of the Print Properties screen, confirm the selections, and then click **OK**.
- 6 Click **OK** or **Print** (depending on the program or operating system).

Print Photos

- 1 Load paper. For help loading photo paper, see page 25.
- 2 With your document open, click **File** → **Print**.
- 3 Click **Preferences** or **Properties**.
- 4 Select the paper size.
- 5 If using photo paper, make sure the glossy side is facing you when you insert the paper into the paper support.
- 6 Click **Print**.
- 7 Remove your photos from the paper exit tray as they are printed to prevent them from sticking together or smearing.



NOTE: Before putting your prints in a nonadhesive photo album or framing them, allow sufficient time for the prints to dry thoroughly (12 to 24 hours, depending on the ambient conditions). This will maximize the life of your prints.

For more printing information, such as how to print collated photocopies and banners, see your *User's Guide*.

Copying

You can use your printer to copy using the printer operator panel or the printer software.

Using the Operator Panel

- 1 Make sure your printer is on.
- 2 Load paper. For help, see page 25.
- 3 Load your document on the scanner glass or into the ADF. For help, see page 28 or page 30.
- 4 From the Mode area on the operator panel, press **Copy** to enter copy mode.
- 5 If you want to make more than one photocopy, press the numbers on the keypad that correspond with the number of photocopies you want to make.
- 6 From the Start area on the operator panel, press **Color** to create a color photocopy of your image or press **Black** to create a black and white photocopy. **Copying** appears on the display.

Using the Printer Software

- 1 Make sure your computer and your printer are on.
- 2 Load paper. For help, see page 25.
- 3 Load your document on the scanner glass or into the ADF. For help, see page 28 or page 30.
- 4 Click **Start** → **All Programs** (or **Programs**) → **Dell Printers** → **Dell AIO Printer A960** → **Dell All-In-One Center**.
The All-In-One Main Page appears on your computer screen.
- 5 Click **See More Copy Settings**.
- 6 Select a quantity and color for your photocopies.



NOTE: You can also choose a paper size or further customize your copy job on this screen.

- 7 Click **Copy Now**.

Copy Photos

- 1 Load paper. For help loading photo paper, see page 26.
- 2 Load your document on the scanner glass or into the ADF. For help, see page 28 or page 30.
- 3 Click **Start** → **All Programs** (or **Programs**) → **Dell Printers** → **Dell AIO Printer A960** → **Dell All-In-One Center**.
The All-In-One Main Page appears on your computer screen.
- 4 Click **Preview Now**.

 **NOTE:** If the size of the scan (found in the lower right of the preview window) appears in red, you do not have the system resources available to perform the scan at the resolution or size you have selected. To correct this problem, either reduce your resolution or the size of your scan area.

- 5 Adjust the dotted lines to fit around the portion of the image you want to print.
- 6 From the Copy section, select **Photo**.
- 7 Select a copy quantity if making multiple photocopies.
- 8 To further customize your photo, click **See More Copy Settings**.
- 9 When you are finished customizing your settings, click **Copy Now**.

Scanning

You can use your printer to scan using the printer operator panel or the printer software.

Using the Operator Panel

- 1 Make sure your computer and printer are on, and the printer is connected to the computer.
- 2 Load your document on the scanner glass or into the ADF. For help, see page 28 or page 30.
- 3 From the Mode area on the operator panel, press **Scan** to put the printer in scan mode.
- 4 Press **+** to scroll through the list of possible programs to which you can scan.
- 5 Press **Select** when the program to which you want to scan appears.
- 6 From the Start area on the operator panel, press **Black** to begin a black and white scan or **Color** to begin a color scan.

Using the Printer Software

 **NOTE:** Some programs do not support multiple page scanning.

- 1 Make sure your computer and printer are on, and the printer is connected to the computer.
- 2 Load your document on the scanner glass or into the ADF. For help, see page 28 or page 30.
- 3 Click **Start** → **All Programs** (or **Programs**) → **Dell Printers** → **Dell AIO Printer A960** → **Dell All-In-One Center**.

The All-In-One Main Page appears on your computer screen.

- 4 Click **Preview Now** to see your scanned image.

 **NOTE:** If the size of the scan (found in the lower right of the preview window) appears in red, you do not have the system resources available to perform the scan at the resolution or size you have selected. To correct this problem, either reduce your resolution or the size of your scan area.

- 5 Adjust the dotted lines to fit around the part of the image you want to print.
- 6 From the Send scanned image to drop-down menu, select your scan destination.
- 7 To further customize your scan job, click **See More Scan Settings**.
- 8 When you are finished customizing your image, click **Scan Now**.

Scan Photos

- 1 Make sure your computer and your printer are on, and the printer is connected to the computer.
- 2 Place your photo on the scanner glass. For help, see page 28.

 **NOTE:** Make sure the upper left corner of the front of the photo aligns with the arrow.

- 3 Click **Start** → **All Programs** (or **Programs**) → **Dell Printers** → **Dell AIO Printer A960** → **Dell All-In-One Center**.

The All-In-One Main Page appears on your computer screen.

- 4 Click **Preview Now** to see your scanned image.

 **NOTE:** If the size of the scan (found in the lower right of the preview window) appears in red, you do not have the system resources available to perform the scan at the resolution or size you have selected. To correct this problem, either reduce your resolution or the size of your scan area.

- 5 Adjust the dotted lines to fit around the portion of the image you want to print.
- 6 From the Send scanned image to drop-down menu, select your scan destination.
- 7 To further customize your scan job, click **See More Scan Settings**.
- 8 When you are finished customizing your image, click **Scan Now**.
- 9 When your document has finished processing, it will open in the program you chose.

Edit Scanned Images

With most graphics programs, you can customize your image.

- 1 From the Dell All-In-One Center, scan your image to the image editor of your choice.
- 2 Edit the image using the tools available in your program.

You may be able to:

- Remove red eye
- Crop your image
- Add text to your image
- Adjust the brightness and contrast of your image

For help, see the documentation that came with your graphics program.

Scan Multiple Pages or Images

 **NOTE:** This feature is only available when scanning from the flatbed scanner.

- 1 Put the first sheet on the scanner glass.
- 2 Click **Start** → **All Programs** (or **Programs**) → **Dell Printers** → **Dell AIO Printer A960** → **Dell All-In-One Center**.
The All-In-One Main Page appears on your computer screen.
- 3 Select your scan destination from the drop-down box.
- 4 In the Scan section, click **See More Scan Settings**
- 5 Click **Display Advanced Scan Settings**.
The Advanced Scan Settings dialog box appears.
- 6 On the Scan tab, select **Scan multiple items before output**.
- 7 Click **OK**.
- 8 When you are finished customizing your settings, click **Scan Now**.

 **NOTE:** You are prompted to put the next item on the scanner glass after the first one scans.

Edit text found in a scanned document using OCR (Optical Character Recognition)

Optical Character Recognition is a software feature that turns a scanned image into editable text within a word processing program.

- 1 Load your document on the scanner glass or into the ADF. For help, see page 28 or page 30.
- 2 Click **Start** → **All Programs** (or **Programs**) → **Dell Printers** → **Dell AIO Printer A960** → **Dell All-In-One Center**.
The All-In-One Main Page appears on your computer screen.
- 3 From the Productivity Tools section, click **Edit text found in a scanned document (OCR)**.
- 4 Follow the instructions on your computer screen.
- 5 When your document has finished processing, it will open in the program you chose.
- 6 Edit your document.
- 7 Save your document.

Save an Image on Your Computer

- 1 Click **Start** → **All Programs** (or **Programs**) → **Dell Printers** → **Dell AIO Printer A960** → **Dell All-In-One Center**.
The All-In-One Main Page appears on your computer screen.
- 2 From the **Productivity Tools** section, click **Save an image on my computer**.
- 3 Follow the directions to save an image on your computer.

E-mail a Scanned Image or Document

You can send scanned images or documents through e-mail:

- 1 Open the top cover.
- 2 Place the photograph or document you want to scan face down on the scanner glass.
- 3 Close the top cover.
- 4 Click **Start** → **All Programs** (or **Programs**) → **Dell Printers** → **Dell AIO Printer A960** → **Dell All-In-One Center**.
The All-In-One Main Page appears on your computer screen.
- 5 Click **Preview Now**.



NOTE: If the size of the scan (found in the lower right of the preview window) appears in red, you do not have the system resources available to perform the scan at the resolution or size you have selected. To correct this problem, either reduce your resolution or the size of your scan area.

- 6 From the **Productivity Tools** area, click **E-mail an image or document**.
- 7 From the **What is being scanned?** menu, select **Photo**.
- 8 Follow the instructions on the screen to prepare the photograph for e-mail.
- 9 Click **Attach Now**.
- 10 Write a note to accompany the attached photo, and then send it.

Enlarge or Reduce Images or Documents

- 1 Load paper in the paper support. For help, see page 25.
- 2 Load your document on the scanner glass or into the ADF. For help, see page 28 or page 30.
- 3 Click **Start** → **All Programs** (or **Programs**) → **Dell Printers** → **Dell AIO Printer A960** → **Dell All-In-One Center**.
The All-In-One Main Page appears on your computer screen.
- 4 Click **Preview Now**.



NOTE: If the size of the scan (found in the lower right of the preview window) appears in red, you do not have the system resources available to perform the scan at the resolution or size you have selected. To correct this problem, either reduce your resolution or the size of your scan area.

- 5 From the Productivity Tools area, select **Enlarge or reduce an image**.
- 6 Follow the instructions on the screen to select the size of your new image.
- 7 When you are finished customizing your image, click **Print Now**.

Faxing

You can fax using the printer operator panel or the printer software.

NOTE: You do *not* need to connect your printer to a computer to send faxes. See "Send a Fax" on page 46 for help using the operator panel to send faxes.

In order to fax using the printer software:

- Your computer must have Dell Printer Fax Tools or Microsoft Fax Console installed and configured
 - See "Using Dell Printer Fax Tools Fax Software" on page 41 to use Dell Printer Fax Tools.
 - See "Using Fax Console (Windows XP Only)" on page 43 to use Fax Console.
- Your computer must be equipped with a data/fax modem.
- An active telephone line must be connected to the line-in connector of your computer's data/fax modem. Do not connect the data/fax modem to the printer's wall jack connector. See page 12 for more information.

NOTE: DSL (digital subscriber line), ISDN (integrated services digital network) and cable modems are *not* fax modems and are *not* supported.

NOTE: Additional devices must be connected to the line-out connector for proper fax operation.

- Your printer must be connected to the computer with a USB cable.

USB cable

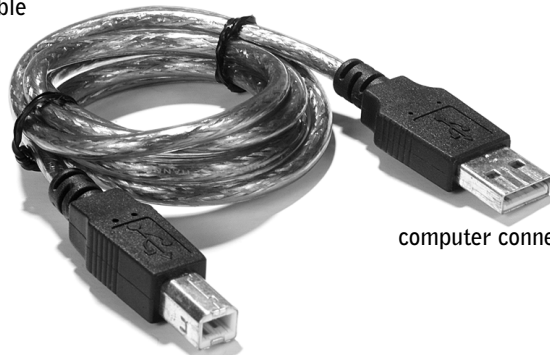

computer connector

printer connector

Using Dell Printer Fax Tools Fax Software

Install Dell Printer Fax Tools Fax Software

- 1** Click the **Start** → **All Programs** (or **Programs**).
A list of your installed software appears.
- 2** Check for any entry referring to **Classic PhoneTools** or **Fax Tools**. If you have either of these entries, skip to “**Configure Dell Printer Fax Tools Fax Software**.”
- 3** Click on the desktop.
The **All Programs** window closes.
- 4** Insert the *Dell Personal All-In-One Printer A960 Drivers and Utilities CD*.
An installation window appears.
- 5** Click **Cancel**.
- 6** Click **Start** → **My Computer**.
- 7** Right-click the **CD Drive** icon.
A drop-down menu appears.
- 8** Click **Explore**.
- 9** Double-click the **Fax** folder.
- 10** Double-click the appropriate language folder.
- 11** Double-click the **Setup** icon.
The **Installation Wizard** appears.
- 12** Follow the instructions on your computer screen to complete the installation.

Configure Dell Printer Fax Tools Fax Software

 **NOTE:** Fax service is set by default to automatically answer your phone line after two rings if you click to select the **Enable Receive** check box. Change these settings as desired.

- 1 Click **Start** → **All Programs** (or **Programs**).
- 2 Click **Dell AIO Printer A960** → **Fax Tools** (or **Classic PhoneTools**).

The fax configuration wizard begins.

- 3 Click **Next**.
- 4 Read the license agreement, and then click **Yes** to continue.
- 5 Enter your name and company name.
- 6 Click **Next**.
- 7 Enter an identifier, phone number, and fax number.
- 8 Click **Next**, click **Next**, click **Next**, and click **Next** again.
- 9 Click **Finish**.

Dell Printer Fax Tools fax software launches.

- 10 Select your country, enter your area code, and enter any number you must press first before getting to an outside line.
- 11 Click **OK**.
- 12 Select your location, and then click **OK**.
- 13 Click **Next**, click **Next**, select your modem, and click **Next** again.
- 14 Click **Next**, click **Next**, and then click **Finish**.

Using Fax Console (Windows XP Only)

Install Fax Console

- 1 Click **Start** → **Control Panel**.
- 2 Click **Add or Remove Programs**.
- 3 Click **Add/Remove Windows Components**.
- 4 Click to select **Fax Services**.
- 5 Click **Next**.
If prompted, insert the *Microsoft Windows XP* CD, and then click **OK**. Close the **Welcome to Microsoft Windows XP** window when it opens.
- 6 Click **Finish**.
- 7 Close the **Add/Remove Programs** window.

Configure Fax Console

- 1 Click **Start** → **All Programs (or Programs)** → **Accessories** → **Communications** → **Fax** → **Fax Console**.

The **Welcome to Fax Configuration Wizard** appears.

- 2 Click **Next**.
- 3 Enter any appropriate information, and then click **Next**.
- 4 Select your data/fax modem in the drop-down menu under **Please select the fax device**.
- 5 Select or de-select the **Enable Send** and **Enable Receive** check boxes as desired, and then click **Next**.



NOTE: De-selecting the **Enable Send** check box prevents you from sending faxes. Selecting the **Enable Receive** check box allows you to receive faxes.

- 6 Enter your **TSID** information, and then click **Next**.
- 7 Enter your **CSID** information, and then click **Next**.
- 8 Click to select **Print it on**. Use the drop-down menu to the right of this field to select **Dell AIO Printer A960** if you want to print all received faxes.
- 9 To create an archive copy of each fax, click to select **Store a copy in a folder**, and then use the **Browse** button to select the desired archive location.
- 10 Click **Next**, confirm your settings, and click **Finish**.

Access the Fax Setup Utility

- Click Start → All Programs (or Programs) → Dell Printers → Dell AIO Printer A960 → Fax Setup Utility
- From the Dell All-In-One Center, click the **Maintain/Troubleshoot** tab, and then click **Display the Fax Setup Utility**.

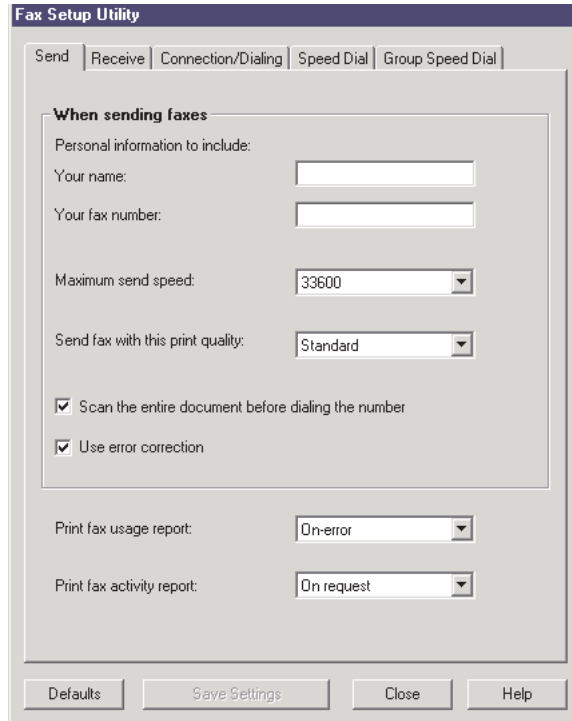

The screenshot shows the 'Fax Setup Utility' dialog box with the 'Send' tab selected. The 'When sending faxes' section contains the following settings:

- Personal information to include:
 - Your name: [Text input field]
 - Your fax number: [Text input field]
- Maximum send speed: 33600 [Dropdown menu]
- Send fax with this print quality: Standard [Dropdown menu]
- Scan the entire document before dialing the number
- Use error correction
- Print fax usage report: On-error [Dropdown menu]
- Print fax activity report: On request [Dropdown menu]

At the bottom of the dialog box, there are four buttons: Defaults, Save Settings, Close, and Help.

The following table describes what you can do from each of the Fax Setup Utility tabs.

On this tab:	You can:
Send	<ul style="list-style-type: none"> • Enter your name and fax number. • Select a maximum send speed and a print quality for outgoing faxes. • Choose whether to scan the entire document before dialing the number. • Choose whether to use error correction. • Select when to print a fax usage report. • Select when to print a fax activity report.
Receive	<ul style="list-style-type: none"> • Choose whether you want to print a footer (date, time, and page number) on each page. • Automatically reduce an incoming fax to fit to the paper size loaded or print it on two sheets of paper. • Select whether you want to forward a fax or print it, and then forward it.
Connection/Dialing	<ul style="list-style-type: none"> • Select the number of times you want the machine to redial and the time between those attempts if the fax cannot be sent on the first try. • Select the phone line format you want to use (Pulse, Touch-tone, Behind a PBX). • Enter a dialing prefix. • Choose how (manually, if fax tones are detected, or after a certain amount of rings) you want to answer incoming calls. • Choose a distinctive ring.
Speed Dial	Add to, create, or edit the speed dial list.
Group Speed Dial	Create a group number and name and add phone numbers to the group.

Send a Fax

 **NOTE:** You can send and receive color faxes using the operator panel only. In order to send a color fax from your printer, the machine to which you are sending the fax must also support color faxes.

You can send faxes using the printer operator panel or the printer software.

Using the Operator Panel

You can use your printer to send color or black and white faxes. You can send and receive A4, legal, and letter size documents.

- 1 Make sure your printer is on.
- 2 Load your document on the scanner glass or into the ADF. For help, see page 28 or page 30.
- 3 Press **Fax**.
- 4 Use the keypad to:
 - Enter the fax number, or
 - Press **Speed Dial**, and then
 - Press **+** or **-** to scroll through the list to find the number you want, or
 - Enter a two-digit number (viewable in the upper left of the display).

 **NOTE:** If you do not have a Speed Dial list, but want to create one, see "Speed Dial" on page 52.

- 5 Press **Black** or **Color**.
The printer scans your document and sends your fax to the number you entered.

Using Dell Printer Fax Tools Fax Software

- 1 Make sure your printer and computer are on.
- 2 Load your document on the scanner glass or into the ADF. For help, see page 28 or page 30.
- 3 Make sure your printer is connected to a computer with a data/fax modem and the modem is connected to an active telephone line.
- 4 Click **Start** → **All Programs** (or **Programs**) → **Dell Printers**, → **Dell AIO Printer A960** → **Dell All-In-One Center**.
- 5 Place the document you want to fax *face down* under the lid of the printer.
- 6 From the Productivity Tools section, select **Fax an image or document**.
- 7 Select the correct option for your document under **What is being scanned**.
- 8 Select **No** under **Is there more than one page**.
- 9 Click **Next**.

The document is scanned and Dell Printer Fax Tools launches.

Send Multiple Page Faxes

You can send multiple page faxes using the printer operator panel or the printer software.

Using the Operator Panel

- 1 Make sure your printer is on and connected to a computer with a data/fax modem and the modem is connected to an active telephone line.
- 2 Load your document into the ADF. For help, see page 30.
- 3 Press **Fax**.
- 4 Enter the fax number using the numbers on the keypad.
- 5 Press **Black** or **Color**.



NOTE: In order to send a color fax from your printer, the machine to which you are sending the fax must also support color faxes.

Using Dell Printer Fax Tools Fax Software

- 1 Click Start → All Programs (or Programs) → Dell Printers → Dell AIO Printer A960 → Dell All-In-One Center.
- 2 Click See More Scan Settings.
- 3 Click Advanced.
- 4 Click to select Scan multiple items before output (flatbed scanner only).
- 5 Click OK.
- 6 Select Fax from the Send scanned image to drop-down menu.
- 7 Place the document you want to fax *face down* under the lid of the printer.
- 8 Click Preview Now.
A preview of your document appears. Adjust your document and repeat if necessary.

 **NOTE:** If the size of the scan (found in the lower right of the preview window) appears in red, you do not have the system resources available to perform the scan at the resolution or size you have selected. To correct this problem, either reduce your resolution or the size of your scan area.

- 9 Click Scan Now.
- 10 Follow the instructions on your computer screen to send your fax.

Receive Faxes

 **NOTE:** Your printer cannot receive soft copy faxes, it can only send them. All incoming faxes print from your printer.

You can receive faxes using the printer operator panel or the printer software. You can choose to receive faxes automatically, manually, or through an answering machine.

Receiving Faxes Through the Printer

For information on receiving faxes through the printer, see the following sections.

- "Receive Faxes Automatically" on page 49.
- "Receive Faxes Manually" on page 49.
- "Receive Faxes Through an Answering Machine" on page 50.

Receiving Faxes with Fax Console

- 1 Click **Start** → **All Programs** (or **Programs**) → **Accessories** → **Communications** → **Fax**.
- 2 Click **Fax Console**.
You are now ready to receive a fax if you selected the **Enable Receive** check box when configuring **Fax Console**.

Receive Faxes Automatically

To reset your printer to automatic answering mode (default):

- 1 From the operator panel, press **Fax**.
- 2 Press **Options** until **Answer fax** when appears.
- 3 Press **+** to scroll through the available options.
- 4 Choose **After 1 ring**, **After 2 rings**, **After 3 rings**, or **After 5 rings**, and then press **Select**.
When the number of rings that you set is detected, the printer automatically receives your fax.



NOTE: For your printer to receive a color fax, the machine from which you are receiving must also support color faxes.

Receive Faxes Manually

- 1 From the operator panel, press **Fax**.
- 2 Press **Options** until **Answer fax** when appears.
- 3 Press **+** to scroll through the available options.
- 4 Press **Select** when **Manual-Press #** appears on the display.
- 5 When it rings, pick up a telephone that is connected to the external jack of the printer and listen for the fax calling tone.
- 6 Press the pound (**#**) key on the telephone.
- 7 Hang up the telephone.
The printer receives your fax.

Receive Faxes Through an Answering Machine

- 1 From the operator panel, press **Fax**.
- 2 Press **Options** until **Answer fax** when appears.
- 3 Press **+** to scroll through the available options.
- 4 When **Fax Tone Heard** appears on the display, press **Select**.

When a ring is detected, the answering machine picks up the call.

- If a fax is detected, the printer receives the fax, and disconnects the answering machine.
- If not, the answering machine completes the call.

Print to Fax

The Print to fax feature eliminates the need to print an original document and put it on the scanner glass to send a fax the conventional way. You can create or receive a soft copy document on your computer and send a black and white fax of it to someone else.

 **NOTE:** You cannot receive soft copy faxes, only send them. All incoming faxes will print from your printer.

To send a fax from your computer program using the fax modem in your printer:

- 1 With your document open, click **File** → **Print**.
- 2 In the printer list, select **Dell Printer Fax Tools**.
- 3 Click **Print**.
- 4 To Print to fax, follow the instructions in the program that launches.

 **NOTE:** All faxes sent using the Print to fax feature use the Fine resolution.

Viewing Sent Faxes and Received Faxes

Using Fax Console

- 1 Click **Start** → **All Programs** (or **Programs**) → **Accessories** → **Communications** → **Fax**.
- 2 Click **Fax Console**.

Received faxes can be viewed in the **Inbox**. Sent faxes can be viewed in **Sent Items**.

View the Status of a Fax

Using Fax Console

- 1 Click **Start** → **All Programs** (or **Programs**) → **Accessories** → **Communications** → **Fax** → **Fax Console**.
- 2 Click to expand the Fax folder, if necessary.
The following folders appear:
 - **Incoming** — faxes currently being received
 - **Inbox** — faxes that have been received
 - **Outbox** — faxes scheduled to be sent
 - **Sent Items** — faxes successfully sent
- 3 Click the folder of your choice.
- 4 In the right pane, click the fax for which you want to view the status, and then click **Preferences** or **Properties**.
- 5 Click the **General** tab and view the Status line.
- 6 Click **Close** when you are finished.

Using Special Fax Features

There are several fax features on your Dell A960 that make sending faxes more efficient.

Speed Dial

To make sending faxes easier, you can enter up to 100 speed dial numbers. You can enter 80 individual fax numbers and 20 groups that can hold up to five phone numbers each.

Using the Operator Panel

- 1 Press **Fax**.
- 2 Press **Speed Dial**.
- 3 The first speed dial number in the list appears.
- 4 Scroll through the list using the **+** or **-** button or use the keypad to enter the two-digit speed dial number.

Using the Printer Software

- 1 Click **Start** → **All Programs** (or **Programs**) → **Dell Printers** → **Dell AIO Printer A960** → **Fax Setup Utility**.
- 2 Click the **Speed Dial** tab.
- 3 Follow the instructions on the Speed Dial tab to add a new number to your speed dial list.

Using Your Speed Dial List

- 1 Press **Speed Dial**, and then:
 - Use the + or - button to scroll through the speed dial list to find the desired fax number, and then press **Fax**.
 - Press the keypad buttons to enter a two-digit number (viewable in the upper left corner of the display), and then press **Fax**.
- 2 When the default screen appears, press **Options**.
- 3 Press **Select**.
- 4 Enter the information about when you want your fax to send.
- 5 Press **Select** again, and then press 1 for AM or 2 for PM.
The default screen appears again.



NOTE: You can repeat this process to enter more numbers to which you want to send a delayed fax.

On Hook Dial

- 1 On the operator panel, press **Fax**.
- 2 Press **Options** repeatedly until **On Hook Dial** appears.
- 3 Press **Select** to make the printer go off hook.
- 4 Enter the number to which you want to send a fax.
- 5 Press the keypad numbers to navigate an automated answering system.
- 6 Press **Black** or **Color** when you are ready to send a fax.

Broadcast Send

If your printer is attached to a computer, you can send a fax of up to 20 pages to as many as five people at once.

To Send a Broadcast Fax Immediately

- 1 Press **Fax**.
- 2 Press **Options** four times to display **Delay Until**.
- 3 Press **+ or -** to display **Do not delay**, and then press **Select**.
- 4 Enter a fax number or press **Speed Dial** to select numbers from your Speed dial list.
- 5 Press **Black** or **Color** to send the fax immediately or press **Select** to enter another fax number.
- 6 Press **Black** or **Color** to send the fax to both numbers or press **Select** to enter another fax number. Continue this procedure until all of the fax numbers (up to five numbers) have been entered.

To Delay Sending a Broadcast Fax

Manually entering a fax number:

- 1 On the operator panel, press **Fax**.
- 2 When the default screen appears, press **Options** until **Delay Until** appears.
- 3 Press **+ or -** to scroll to **Time**.
- 4 Press **Select**.
- 5 Enter the time you want your fax to send.
- 6 Press **Select**.
- 7 If your printer is in 24-hour mode, the screen will return to the default display. If the machine is set to 12-hour mode, press **1** for AM or **2** for PM.
- 8 Using the keypad, enter the fax number.
- 9 Press **Black** or **Color** to send your fax to this number or press **Select** to enter another fax number (you can do this up to five times and the delayed fax will be sent to as many numbers as you entered).



NOTE: At the designated time, the fax numbers are dialed and the fax transmitted to all of the designated fax numbers. If the fax transmission is unsuccessful to any of the numbers on the broadcast list, the unsuccessful numbers will be tried again at the end of the list.

SECTION 3

Understanding the Software

Using the Dell All-In-One Center

Using Print Properties

Using the Dell Printer Solution Center

Using Dell Picture Studio

Understanding the Printer Software

The printer software includes the:

- Dell All-In-One Center—helps you perform various scan, copy, and fax operations and manage your saved images.
 - Print Properties—helps you adjust printing settings.
 - Dell Printer Solution Center—provides maintenance and troubleshooting help, provides basic usage information, and How to's for creating projects.
 - Dell Picture Studio—helps you edit your photos.
-  **NOTE:** Your language may not be supported. If your language is not supported, use the photo editing software in your Windows operating system.
- Fax Setup Utility (page 44)

Using the Dell All-In-One Center

You can use the Dell All-In-One Center to:

- Select a scan destination.
- Select a photocopy quantity and color.
- Scan, copy, print, fax, and do creative tasks.
- Access troubleshooting and maintenance information.
- Preview images you want to print.
- Manage photos (copy them to folders, print them, do creative copying) using the View Saved Images tab.

Access the Dell All-In-One Center:

- Click Start → All Programs (or Programs) → Dell Printers → Dell AIO Printer A960 → Dell All-In-One Center.

The All-In-One Main Page

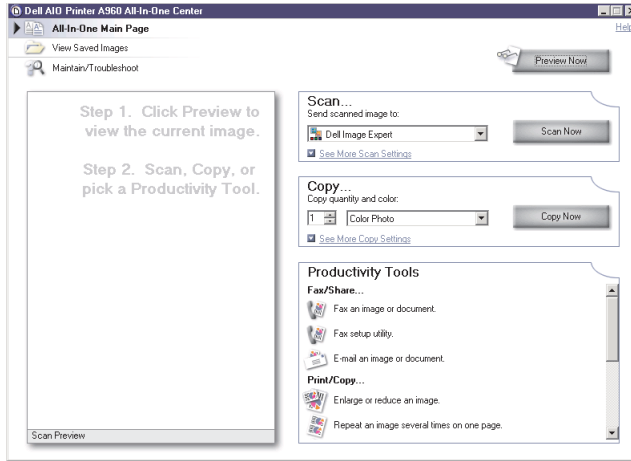

The All-In-One Main Page consists of four main sections. The following table describes each of the sections.

From this section:	You can:
Scan	<ul style="list-style-type: none"> • Select a program to send the scanned image to. • Choose what type of image is being scanned. • Choose how the scan will be used. <p>NOTE: Click See More Scan Settings to view all settings.</p>
Copy	<ul style="list-style-type: none"> • Select the quantity and color of your photocopies. • Select a quality setting for your photocopies. • Adjust the size of the scanned area. • Lighten or darken your photocopies. • Enlarge or reduce your photocopies. <p>NOTE: Click See More Copy Settings to view all settings.</p>

From this section:	You can:
Productivity Tools	Choose from a variety of creative ideas. <ul style="list-style-type: none">• Fax an image or document.• Enlarge or reduce an image.• Repeat an image several times on one page.• Print an image as a multi-page poster.• E-mail an image to a friend.• Save an image on your computer.• Edit text found in a scanned document (Optical Character Recognition).• Modify an image with a photo editor.
Preview section	<ul style="list-style-type: none">• Select a region of the preview image to scan.• View an image of what will be printed or copied.

For more information on using the Dell All-In-One Center, see your *User's Guide*.



NOTE: For more information about the All-In-One Main Page, View Saved Images Page, or the Maintain/Troubleshoot Page, click the **Help** button located in the upper right corner of the screen.

Using Print Properties

You can change your printer settings in Print Properties.

Access Print Properties

- 1 With your document open, click **File** → **Print**.
The Print dialog box appears.
- 2 In the Print dialog box, click **Preferences** or **Properties** (depending on your program or operating system).
The Print Properties screen appears along with the I Want To menu.

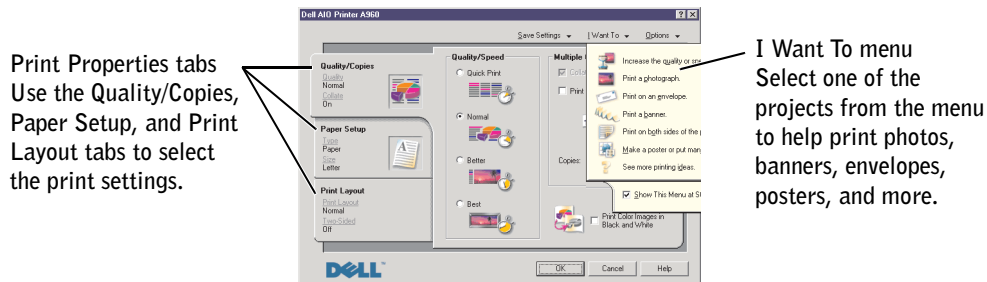

To access Print Properties when a document is not open:

- 1 Click **Start** → **Printers**.
- 2 Right-click on the printer icon, and then choose **Printer Preferences**.

Print Properties Tabs

All of the print settings are on the three main tabs of the Print Properties software. The following table describes each of the tabs.

From this tab:	You can change these settings:
Quality/Copies	<p>Quality/Speed—Select a Quality/Speed setting.</p> <p>Multiple Copies—Customize how the printer prints several photocopies of a single print job: collated or normal.</p> <p>Print Color Images in Black and White—To print your color images in black and white.</p>

From this tab:	You can change these settings:
Paper Setup	Type —Select the type of media you are using. Paper Size —Select the size of the paper you are using. Orientation —Select how you want the document oriented on the printed page. You can print with portrait or landscape orientation.
Print Layout	Layout —Select the layout you want to print. Duplexing —Select this when you want to print on both sides of the paper.

 **NOTE:** For additional information about these settings, right-click a setting on the screen, and then select the **What's This?** item.

To learn more about Print Properties, see your *User's Guide*.

Using the Dell Printer Solution Center

The Dell Printer Solution Center is a guide you can refer to for printer help and to check the current printer status.

Access the Dell Printer Solution Center

Click Start → All Programs (or Programs) → Dell Printers → Dell AIO Printer A960 → Dell Printer Solution Center.

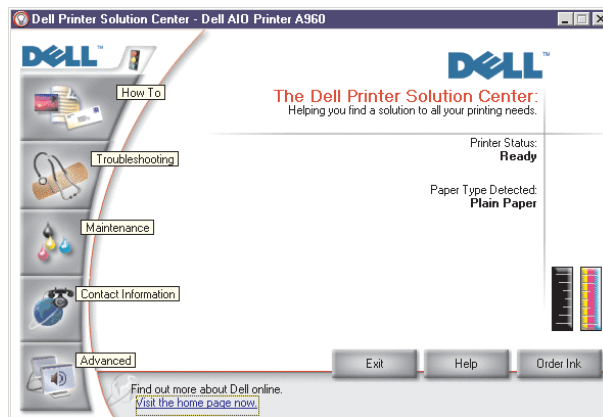

To learn more about the Dell Printer Solution Center, see your *User's Guide*.

Using Dell Picture Studio

 **NOTE:** Dell Picture Studio is included on your *Drivers and Utilities* CD.

Dell Picture Studio lets you adjust photo attributes. With Dell Picture Studio, you can:

Eliminate red eye	Rotate images	Attach images to e-mail
Add text to images	Resize images	Create and share slideshows
Add special effects	Create Web pages	Make a series of images into a movie

Access Dell Picture Studio

- Click **Start** → **All Programs** (or **Programs**) → **Dell Picture Studio Home**.

 **NOTE:** Your language may not be supported. If your language is not supported, use the photo editing software in your Windows operating system.

SECTION 4

Ink Cartridge Maintenance

Replacing Ink Cartridges

Aligning Ink Cartridges

Cleaning the Ink Cartridge Nozzles

Replacing Ink Cartridges

 **CAUTION:** Before performing any of the procedures listed in this section, read and follow the Safety Instructions on page 4.

Dell™ ink cartridges are available only through Dell. You can order more ink at www.dell.com/supplies.

- 1 Make sure the printer is on.
- 2 Lift the printer (scanner unit) until the scanner support keeps it open.
The ink cartridge carrier moves and stops at the loading position unless the printer is busy.
- 3 Squeeze the tabs on the cartridge lids, and then lift the lids.
- 4 Remove the old cartridges. Store them in an air-tight container or dispose of them.
- 5 If you are installing new cartridges, remove the stickers and transparent tape from the bottom of the cartridges.

 **NOTICE:** Do *not* touch the gold contact area on the cartridges.

- 6 Insert the new cartridges. Make sure the black ink cartridge is secure in the left (black) cartridge carrier and the color cartridge is secure in the right (blue) cartridge carrier, and then snap the lids closed.
- 7 Lift the printer (scanner unit), and then push the scanner support to the right while lowering the printer (scanner unit) until it is completely closed.
- 8 Load paper into the paper support.
- 9 Use the buttons on the operator panel to answer the questions that appear on the display:
 - a If the color cartridge you installed is new (it has never been used), press **Select**.
If it is old (it has been used), press **+** once, and then press **Select**.
 - b If the part number that appears is the number of the cartridge you are using, press **Select**.
If it is not the number of the cartridge you are using, press **+** until the correct part number appears, and then press **Select**.
 - c If the black cartridge you installed is new, press **Select**.
If it is old, press **+** once, and then press **Select**.

The part number that appears should be the number of the cartridge you are using.

- d Press **Select** to choose the part number that appears.
- e Continue with **Aligning Ink Cartridges** to ensure proper installation.

Aligning Ink Cartridges

Align your ink cartridges after installing new cartridges and to solve print quality problems.

Using the Operator Panel

- 1 Load plain paper. For help, see page 25.
- 2 On the operator panel, press **Copy**.
- 3 Press **Options** until **Maintenance** appears.
- 4 Press **+** until **Align** appears, and then press **Select**.
Alignment Page Printing appears on the display, and an alignment page prints.
Once the alignment page prints, your automatic alignment is complete.

Using the Printer Software to Automatically Align Ink Cartridges

When automatically aligning your ink cartridges, a page prints with vertical, horizontal, and slanted lines.

- 1 Load paper. For help, see page 25.
- 2 Click **Start** → **All Programs** (or **Programs**) → **Dell Printers** → **Dell AIO Printer A960** → **Dell Printer Solution Center**.
- 3 From the **Maintenance** tab, click **Align to fix blurry edges**.
- 4 Click **Print**.
An alignment page prints.

Using the Printer Software to Manually Align Ink Cartridges

When manually aligning your ink cartridges, a page prints with arrows followed by numbers.

- 1** Load paper. For help, see page 25.
- 2** Click **Start** → **All Programs** (or **Programs**) → **Dell Printers** → **Dell AIO Printer A960** → **Dell Printer Solution Center**.
- 3** From the Maintenance tab, click **Align to fix blurry edges**.
- 4** Click **Manual Alignment**, and then click **Print**.
An alignment page prints.
- 5** Find the number under the darkest arrow for each alignment group.
- 6** Use the arrows in the Align Cartridges dialog box to select the number that matches the arrow you chose from the printed page.
- 7** Once you have selected a number for each of the alignment groups, click **OK**.

Cleaning the Ink Cartridge Nozzles

Clean the nozzles when:

- Characters are not printing completely
- White dashes appear in graphics or printed text.
- Print is smudged or too dark.
- Colors on print jobs are faded or they differ from the colors on the screen.
- Vertical, straight lines are not smooth.

Using the Operator Panel

- 1 Load paper. For help, see page 25.
- 2 Press **Copy**.
- 3 Press **Options** until **Maintenance** appears on the display.
- 4 Press **+** until **Clean** appears on the display.
- 5 Press **Select**.
A nozzle page prints, forcing ink through the clogged nozzles to clean them.
- 6 Print your document again to verify that your print quality has improved.
If you are not satisfied with the print quality, continue with wiping the ink cartridge nozzles and contacts. For help, see your *User's Guide*.

Using the Printer Software

- 1 Load paper. For help, see page 25.
- 2 Click **Start** → **All Programs** (or **Programs**) → **Dell Printers** → **Dell AIO Printer A960** → **Dell Printer Solution Center**.
- 3 From the **Maintenance** tab, click **Clean to fix horizontal streaks**.
- 4 Click **Print**.
A nozzle page prints, forcing ink through the nozzles to clean the clogged nozzles.
- 5 Print your document again to verify that your print quality has improved.
- 6 If you are not satisfied with the print quality, wipe the print cartridge nozzles. For help, see your *User's Guide*.

SECTION 5

Troubleshooting

Setup Problems

General Problems

More Troubleshooting Options

Setup Problems

If you experience problems while setting up your printer, make sure:

- You unlock the scanner bed by pushing the scanner lock down. For help locating the scanner lock, see the picture of the printer on page 11.
- You select your language and default country, and then press **Select** on the operator panel.

If you skipped selecting your language, default country, date, time, or fax number during the setup process, see:

"Display Language Is Not Preferable" on page 74.

"Default Country Was Not Set" on page 74.

"Fax Settings Are Unsatisfactory" on page 74.

"Date and Time on the Display Are Incorrect" on page 74.

- You only have one Dell AIO Printer A960 attached to your computer.
- Your operating system is compatible with your printer. The Dell AIO Printer A960 supports Windows XP and Windows 2000.

General Problems

Try to troubleshoot your problem before contacting Dell by checking the following items.

If your printer is *not* attached to a computer, make sure:

- You read and follow any scrolling text messages on the display.
- The power supply is plugged into your printer and an electrical outlet.

If your printer *is* attached to a computer, make sure:

- The USB cable (sold separately) is securely attached to your computer and to your printer.
- Both your computer and your printer are on.
- The Dell AIO Printer A960 is set as your default printer.

Anytime your printer has a problem, make sure:

- Your printer is on.
- The scanner is unlocked. For help locating the scanner lock, see the picture of the printer on page 11.
- You removed the stickers and tape from the bottom of the ink cartridges. For help, see the *Setup Diagram*.
- The paper is loaded correctly. For help, see "Loading Paper" on page 25
- You installed both of the ink cartridges. The Dell AIO Printer A960 only works if you have both cartridges installed. For help installing the cartridges, see the *Setup Diagram*.
- Disconnect, and then reconnect both ends of the USB cable. For help, see the *Setup Diagram*.
- Unplug the power supply from the electrical outlet. Reconnect the power supply (see your setup documentation). Turn the power on.
- Restart your computer. If problems persist, see "Uninstalling and reinstalling the software" in your *User's Guide*. For help accessing your *User's Guide*, see page 13.

Document Does Not Print

- Make sure the cartridges are properly installed.
- Use an undamaged USB cable.
- Check your printer status to make sure your document is not being held or paused. To check printer status:
 - a Click **Start** → **Control Panel** → **Printers and Other Hardware** → **Printers and Faxes** (Windows XP).
Click **Start** → **Settings** → **Printers and Faxes** or **Printers** (Windows 2000).
 - b Double-click the **Dell AIO Printer A960** icon, and then click **Printer**.
 - c Click **Printer**, and make sure no check mark appears next to **Pause Printing**.
- Print a test page:
 - a Click **Start** → **All Programs** (or **Programs**) → **Dell Printers** → **Dell AIO Printer A960** → **Dell Printer Solution Center**.
 - b Click the **Maintenance** tab.
 - c From the Maintenance tab, click **Print a test page**.

Black and White Copy Quality Is Unsatisfactory

You might need to change an Advanced Copy Setting in the All-In-One Center.

If You Are Copying In Black and White and Want To Improve the Quality:

- 1 Click **Start** → **All Programs** (or **Programs**) → **Dell Printers** → **Dell AIO Printer A960** → **Dell All-In-One Center**.

The All-In-One Main Page appears on your computer screen.

- 2 In the Copy section, click **See More Copy Settings**.
- 3 Click **Advanced** to display the Advanced Copy Settings dialog box.
- 4 Click the **Scan** tab.
- 5 From the Color depth drop down menu, select **Gray**.
- 6 Click **OK**.

Scanner Unit Will Not Close

To close the scanner unit after installing ink cartridges, unlocking the scanner bed, or removing a paper jam, follow these steps:

- 1 Using both hands, lift the scanner unit.
- 2 With one hand, push the scanner support to the side.
- 3 Hold the scanner support to the side as you lower the scanner unit.

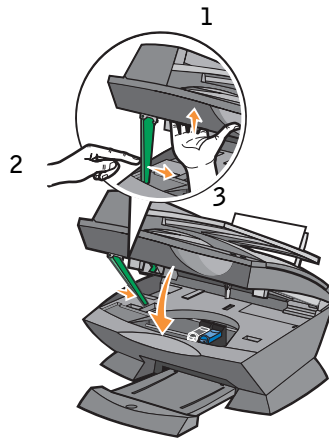

 **NOTE:** Make sure the scanner unit closes completely.

Printer Is Scanning and Copying Without a Pre-Scan

- 1 On the operator panel, press **Scan** or **Copy**.
- 2 Press **Options** until **ORIGINAL SIZE** appears.
Press **Select** to choose **Auto Detect** (default).
- 3 On the operator panel, press **Reduce/Enlarge** and then press **+** until **Fit to Page** appears.
- 4 Press **Color** or **Black**.

The scanner pre-scans your original document to determine its size, fits it onto the specified paper size, and then scans your original document.



NOTE: Resizing an image may affect the scan and copy quality of your document.

Fax Does Not Work

In order for faxing to function properly:

- The printer must be connected to an active phone line.
- If you are using the printer software to fax, the printer must be connected to a computer with a USB cable.
- The memory may be full. Wait until the faxes in memory have been sent, and then send the current fax again.



NOTE: You cannot fax with a DSL (digital subscribe line), ISDN (integrated signature digital network), or cable modem.

- 5 For more information, see "Faxing" on page 40.

Printer Is Not Sending or Receiving Faxes

If you are having trouble sending or receiving a fax through the printer software, ensure that:

- Your computer is connected to a working data/fax modem.
- An active phone line is connected to the line-in connector of your data/fax modem.
- Fax software is installed and configured on your computer.
- Your printer is connected to the computer with a USB cable.

Display Language Is Not Preferable

If the language on the printer display is not the language you prefer, change the language:

- 1 On the operator panel, press **Options** until **LANGUAGE** displays.
- 2 Use **+** to scroll through the list of languages.
- 3 When your preferred language displays, press **Select** to set that language as the default.

Default Country Was Not Set

If you did not select the default country during the setup process:

- 1 Press **Fax** on the printer operator panel.
- 2 Press **Options** repeatedly until **Advanced Fax** appears on the display.
- 3 Press **+** repeatedly until **Country code** appears on the display, and then press **Select**.
- 4 Press **+** until your preferred your country appears on the display, and then press **Select** to set that country as the default.

Fax Settings Are Unsatisfactory

- 1 Click **Start** → **All Programs** (or **Programs**) → **Dell Printers** → **Dell AIO Printer A960** → **Dell All-In-One Center**.
The All-In-One Main Page appears on your computer screen.
- 2 In the upper left corner, click **Maintain/Troubleshoot**.
- 3 Under Fax Setup Utility, click **Display the Fax Setup Utility**.
- 4 Adjust the settings you want to change.
- 5 Click **Save Settings**.

Date and Time on the Display Are Incorrect

To set the current date and time:

- 1 On the operator panel, press **Fax**.
- 2 To change the date:
 - a Press **Options** until **EDIT DATE/TIME:** appears on the display.
 - b Press **Select**.

- c Use the keypad buttons to enter the date you want your printer to display.
- d Press **Select**.

 **NOTE:** If the date is entered incorrectly, the date shown will be the default.

3 To change the time:

- a Press **Options** until **EDIT DATE/TIME:** appears on the display.
- a Press **+** once, and then press **Select**.
- b Use the keypad buttons to enter the time you want your printer to display.
- c Press **Select**.
- d Press **1** for AM, **2** for PM, or **3** for 24-hour time.

 **NOTE:** If the time is entered incorrectly, the time shown will be the default.

Paper Misfeeds or Multiple Sheets Feed

- Use a paper recommended for inkjet printers.
- Do not force the paper into the printer.
- Do not load too much paper into the printer. For help, see page 26.
- Make sure the paper guide rests against the left edge of the paper and does not cause the paper to bow in the paper support.

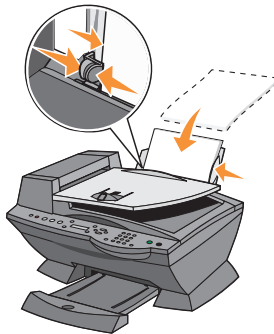

- Place the printer on a flat, level surface.
- Select the correct paper type and size.

Paper Jams

If a paper jam occurs in the paper support, remove the paper from the printer. If the paper is lodged too far into the printer and cannot be removed:

- 1 Press **Power** to turn the printer off.
- 2 Pull slowly and firmly on the paper to remove it.

If you cannot reach the paper because it is too far into the printer:

- a Lift the scanner unit, and then pull the paper out.

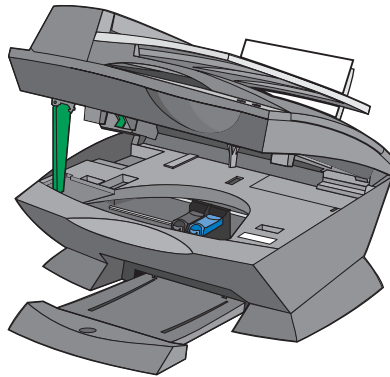

- b Lower the scanner unit to close it.

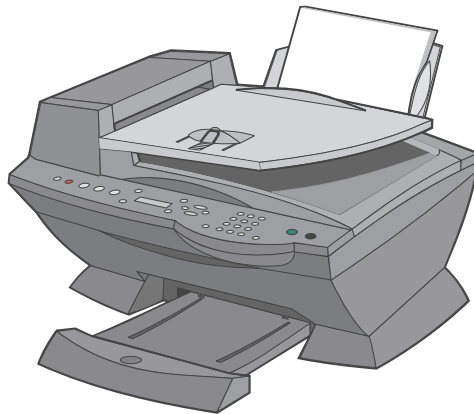

- 3 Press **Power** to turn the printer on, and then print your document.

Document Misfeeds or Jams

- 1 Turn the printer off.
- 2 Open the ADF.

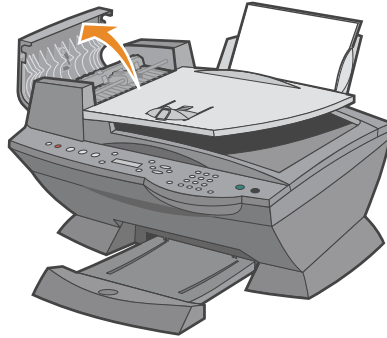

- 3 Pull gently to remove the paper jam.
- 4 Close the ADF.
- 5 Turn the printer on.
- 6 Print any missing pages.

Error Messages and Flashing Lights

Use this section to understand printer software error messages on your computer screen or operator panel display and blinking lights on your printer.

Ink Low Message

An ink cartridge is running out of ink. The Ink Low warning occurs when your cartridges are about 25% full, 15% full, and 5% full. When one of these messages appears, you can:

- Click **OK**.
- Click the **?** to get information about ordering supplies.
- Order a new cartridge from Dell at www.dell.com/supplies.

For help installing a new cartridge, see page 64.

Paper Jam Message

If your printer has a paper jam:

- 1 Click **Start** → **All Programs** (or **Programs**) → **Dell Printers** → **Dell AIO Printer A960** → **Dell Printer Solution Center**.
- 2 Click the **Troubleshooting** tab on the left side of the screen.
- 3 Click **How to clear and avoid paper jams**.
- 4 Follow the instructions to clear the paper jam.

Paper Out Message

If your printer is out of paper, **Load paper** then **press Select** appears on the display.

- 1 Follow these instructions to clear the message from the display.
- 2 Print your document.

Hardware Error: 0402

The printer has a paper jam in the ADF. See "Document Misfeeds or Jams" on page 77 to clear the jam.

Hardware Error: 401

The printer scanner is stalled.

- 1 Press **Power** to turn your printer off.
- 2 Unplug your printer.
- 3 Make sure the scanner is unlocked.
- 4 Plug in your printer.
- 5 Press **Power** to turn your printer on.

Cartridge Error: 50C

Your ink cartridge has a short.

- 1 Press **Power** to turn your printer off.
- 2 Unplug your printer.
- 3 Plug in your printer.
- 4 Turn your printer on.
- 5 Uninstall and reinstall the cartridges.



NOTE: If this does not resolve the problem, see "More Troubleshooting Options" on page 82 or replace your cartridges.

Hardware Error: 502

The printer is stalled.

- 1 Press **Power** to turn your printer off.
- 2 Unplug your printer.
- 3 Check for paper jams.
- 4 Plug in your printer.
- 5 Press **Power** to turn your printer on.

Power Light Blinks Twice

The ink cartridge carrier might be stalled. Check your computer screen for error messages.

- 1 Turn the printer off.
- 2 Wait a few seconds, and then turn the printer on.

Improving Print Quality

If you are not satisfied with the print quality of your document, make sure you:

- Use the appropriate paper for the document.
- Use paper that is a heavier weight, bright white, or coated. Use Dell™ Premium Photo Paper for printing photos.
- Select a higher print quality:
 - a From your software program, click **File** → **Print**.
The Print dialog box appears.
 - b From the Print dialog box, click **Preferences** or **Properties**.
 - c From the Quality/Speed area, select **Better** or **Best**.

If your document still does not have the print quality you want, follow these steps:

Reinsert the Ink Cartridges

- 1 Remove the ink cartridges.
- 2 Insert the ink cartridges.
- 3 Print your document again.
- 4 If print quality has not improved, continue with "Cleaning the Ink Cartridge Nozzles" on page 67.

Clean the Ink Cartridge Nozzles

Clean the nozzles when:

- Characters are not printing completely
- White dashes appear in graphics or printed text.
- Print is smudged or too dark.
- Colors on print jobs are faded or they differ from the colors on the screen.
- Vertical, straight lines are not smooth.

For help, see "Cleaning the Ink Cartridge Nozzles" on page 67.

Remove and Reinstall the Software

If the All-In-One is not functioning properly or if a communications error message appears when you try to use your printer, you may need to remove the printer software, and then reinstall it.

- 1** Click **Start** → **All Programs** (or **Programs**) → **Dell Printers** → **Dell AIO Printer A960** → **Uninstall Dell AIO Printer A960**.
- 2** Follow the instructions on your screen to remove the All-In-One software.
- 3** Restart your computer before reinstalling the printer software.
- 4** Insert the *Driver and Utilities* CD, and then follow the instructions on your screen to install the software.

More Troubleshooting Options

See the *User's Guide* if you experience any of the following problems:

- Document Prints Slowly
- Document Prints Poorly
- Transparencies or Glossy Photo Papers Stick Together
- Transparencies or Photo Papers Contain White Lines
- Auto-cropping of Scanned Image Is Unsatisfactory
- Edges of My Document Are Cut Off
- Scanned Image is Unsatisfactorily Cropped
- Copied Objects Appear In a Different Location on the Page
- Fit to Page Function Is Not Working Properly
- Auto Detect Is Set But Not Working Properly

If the preceding solutions do not solve the problem you are having with your printer:

- See the Dell Printer Solution Center software for more troubleshooting information:
 - a** Click **Start** → **All Programs** (or **Programs**) → **Dell Printers** → **Dell AIO Printer A960** → **Dell Printer Solution Center**.
 - b** Click the **Troubleshooting** tab on the left side of the screen.
- Go to support.dell.com for help.

SECTION 6

Contacting Dell

Technical Assistance

If you need help with a technical problem, Dell is ready to assist you.

- 1 Call technical support from a telephone near or at the printer so that technical support can assist you with any necessary procedures. When calling Dell, use your Express Service Code to help expedite the routing of your call to the proper support personnel.

The Express Service Code is located on the printer as shown below.

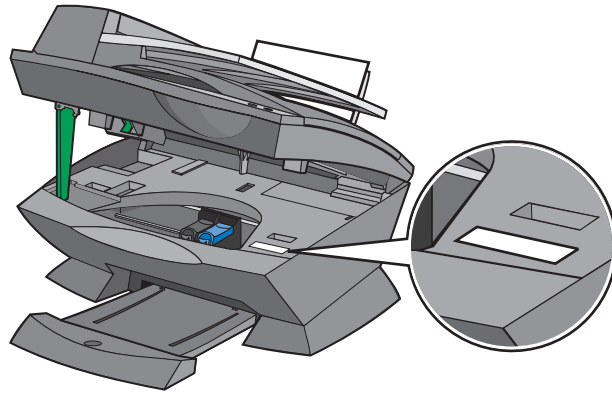

NOTE: Dell's Express Service Code system may not be available in all countries.

- 2 In the U.S., Business customers should call 1-877-459-7298, and Consumer (Home and Home Office) customers should call 1-800-624-9896.

If you are calling from a different country or are in a different Service area, see "Contacting Dell" for your local telephone number.

- 3 Follow the menu prompts in the automated telephone system to speak with a technical support representative.

Automated Order-Status Service

To check on the status of any Dell™ products that you have ordered, you can go to support.dell.com, or you can call the automated order-status service. A recording prompts you for the information needed to locate and report on your order. See "Contacting Dell" for the telephone number to call for your region.

Contacting Dell

To contact Dell electronically, you can access the following websites:

- www.dell.com
- support.dell.com (technical support)
- premiersupport.dell.com (technical support for educational, government, healthcare, and medium/large business customers, including Premier, Platinum, and Gold customers)

For specific web addresses for your country, find the appropriate country section in the table below.

NOTE: Toll-free numbers are for use within the country for which they are listed.

When you need to contact Dell, use the electronic addresses, telephone numbers, and codes provided in the following table. If you need assistance in determining which codes to use, contact a local or an international operator.

Country (City) International Access Code Country Code City Code	Department Name or Service Area, Website and E-Mail Address	Area Codes, Local Numbers, and Toll-Free Numbers
U.S.A. (Austin, Texas)	Automated Order-Status Service	toll-free: 1-800-433-9014
International Access Code: 011	AutoTech (portable and desktop computers)	toll-free: 1-800-247-9362
Country Code: 1	Consumer (Home and Home Office)	
	Technical Support	toll-free: 1-800-624-9896
	Customer Service	toll-free: 1-800-624-9897
	DellNet™ Service and Support	toll-free: 1-877-Dellnet (1-877-335-5638)
	Employee Purchase Program (EPP) Customers	toll-free: 1-800-695-8133
	Financial Services website: www.dellfinancialservices.com	
	Financial Services (lease/loans)	toll-free: 1-877-577-3355
	Financial Services (Dell Preferred Accounts [DPA])	toll-free: 1-800-283-2210
	Business	
	Customer Service and Technical Support	toll-free: 1-877-459-7298
	Employee Purchase Program (EPP) Customers	toll-free: 1-800-695-8133
	Projectors Technical Support	toll-free: 1-877-459-7298
	Public (government, education, and healthcare)	
	Customer Service and Technical Support	toll-free: 1-800-456-3355
	Employee Purchase Program (EPP) Customers	toll-free: 1-800-234-1490
	Dell Sales	toll-free: 1-800-289-3355 or toll-free: 1-800-879-3355
	Dell Outlet Store (Dell refurbished computers)	toll-free: 1-888-798-7561
	Software and Peripherals Sales	toll-free: 1-800-671-3355
	Spare Parts Sales	toll-free: 1-800-357-3355
	Extended Service and Warranty Sales	toll-free: 1-800-247-4618
	Fax	toll-free: 1-800-727-8320

Country (City) International Access Code Country Code City Code	Department Name or Service Area, Website and E-Mail Address	Area Codes, Local Numbers, and Toll-Free Numbers
Belgium (Brussels)	Website: support.euro.dell.com	
International Access Code: 00	E-mail: tech_be@dell.com	
Country Code: 32	E-mail for French Speaking Customers: support.euro.dell.com/be/fr/emailldell/	
City Code: 2	Technical Support	02 481 92 88
	Customer Care	02 481 91 19
	Corporate Sales	02 481 91 00
	Fax	02 481 92 99
	Switchboard	02 481 91 00
Canada (North York, Ontario)	Online Order Status: www.dell.ca/ostatus	
International Access Code: 011	AutoTech (automated technical support)	toll-free: 1-800-247-9362
	TechFax	toll-free: 1-800-950-1329
	Customer Care (Home Sales/Small Business)	toll-free: 1-800-847-4096
	Customer Care (med./large business, government)	toll-free: 1-800-326-9463
	Technical Support (Home Sales/Small Business)	toll-free: 1-800-847-4096
	Technical Support (med./large bus., government)	toll-free: 1-800-387-5757
	Sales (Home Sales/Small Business)	toll-free: 1-800-387-5752
	Sales (med./large bus., government)	toll-free: 1-800-387-5755
	Spare Parts Sales & Extended Service Sales	1 866 440 3355

Country (City) International Access Code Country Code City Code	Department Name or Service Area, Website and E-Mail Address	Area Codes, Local Numbers, and Toll-Free Numbers
Denmark (Copenhagen)	Website: support.euro.dell.com	
International Access Code: 00	E-mail Support (portable computers): den_nbk_support@dell.com	
Country Code: 45	E-mail Support (desktop computers): den_support@dell.com	
	E-mail Support (servers): Nordic_server_support@dell.com	
	Technical Support	7023 0182
	Customer Care (Relational)	7023 0184
	Home/Small Business Customer Care	3287 5505
	Switchboard (Relational)	3287 1200
	Fax Switchboard (Relational)	3287 1201
	Switchboard (Home/Small Business)	3287 5000
	Fax Switchboard (Home/Small Business)	3287 5001
Finland (Helsinki)	Website: support.euro.dell.com	
International Access Code: 990	E-mail: fin_support@dell.com	
Country Code: 358	E-mail Support (servers): Nordic_support@dell.com	
City Code: 9	Technical Support	09 253 313 60
	Technical Support Fax	09 253 313 81
	Relational Customer Care	09 253 313 38
	Home/Small Business Customer Care	09 693 791 94
	Fax	09 253 313 99
	Switchboard	09 253 313 00

Country (City) International Access Code Country Code City Code	Department Name or Service Area, Website and E-Mail Address	Area Codes, Local Numbers, and Toll-Free Numbers
France (Paris) (Montpellier) International Access Code: 00 Country Code: 33 City Codes: (1) (4)	Website: support.euro.dell.com E-mail: support.euro.dell.com/fr/fr/emaildell/ Home and Small Business Technical Support Customer Care Switchboard Switchboard (calls from outside of France) Sales Fax Fax (calls from outside of France) Corporate Technical Support Customer Care Switchboard Sales Fax	 0825 387 270 0825 823 833 0825 004 700 04 99 75 40 00 0825 004 700 0825 004 701 04 99 75 40 01 0825 004 719 0825 338 339 01 55 94 71 00 01 55 94 71 00 01 55 94 71 01
Germany (Langen) International Access Code: 00 Country Code: 49 City Code: 6103	Website: support.euro.dell.com E-mail: tech_support_central_europe@dell.com Technical Support Home/Small Business Customer Care Global Segment Customer Care Preferred Accounts Customer Care Large Accounts Customer Care Public Accounts Customer Care Switchboard	 06103 766-7200 0180-5-224400 06103 766-9570 06103 766-9420 06103 766-9560 06103 766-9555 06103 766-7000

Country (City) International Access Code Country Code City Code	Department Name or Service Area, Website and E-Mail Address	Area Codes, Local Numbers, and Toll-Free Numbers
Greece	Website: support.euro.dell.com	
International Access Code: 00	E-mail: support.euro.dell.com/gr/en/emaildell/	
Country Code: 30	Technical Support	080044149518
	Gold Technical Support	08844140083
	Switchboard	2108129800
	Sales	2108129800
	Fax	2108129812
India	Technical Support	1600 33 8045
	Sales	1600 33 8044
Ireland (Cherrywood)	Website: support.euro.dell.com	
International Access Code: 16	E-mail: dell_direct_support@dell.com	
Country Code: 353	Ireland Technical Support	1850 543 543
City Code: 1	U.K. Technical Support (dial within U.K. only)	0870 908 0800
	Home User Customer Care	01 204 4014
	Small Business Customer Care	01 204 4014
	U.K. Customer Care (dial within U.K. only)	0870 906 0010
	Corporate Customer Care	1850 200 982
	Corporate Customer Care (dial within U.K. only)	0870 907 4499
	Ireland Sales	01 204 4444
	U.K. Sales (dial within U.K. only)	0870 907 4000
	Fax/SalesFax	01 204 0103
	Switchboard	01 204 4444

Country (City) International Access Code Country Code City Code	Department Name or Service Area, Website and E-Mail Address	Area Codes, Local Numbers, and Toll-Free Numbers
Italy (Milan) International Access Code: 00 Country Code: 39 City Code: 02	Website: support.euro.dell.com	
	E-mail: support.euro.dell.com/it/it/emaildell/	
	Home and Small Business	
	Technical Support	02 577 826 90
	Customer Care	02 696 821 14
	Fax	02 696 821 13
	Switchboard	02 696 821 12
	Corporate	
	Technical Support	02 577 826 90
	Customer Care	02 577 825 55
	Fax	02 575 035 30
	Switchboard	02 577 821
	Latin America	Customer Technical Support (Austin, Texas, U.S.A.)
Customer Service (Austin, Texas, U.S.A.)		512 728-3619
Fax (Technical Support and Customer Service) (Austin, Texas, U.S.A.)		512 728-3883
Sales (Austin, Texas, U.S.A.)		512 728-4397
SalesFax (Austin, Texas, U.S.A.)		512 728-4600
		or 512 728-3772
Luxembourg International Access Code: 00 Country Code: 352	Website: support.euro.dell.com	
	E-mail: tech_be@dell.com	
	Technical Support (Brussels, Belgium)	3420808075
	Home/Small Business Sales (Brussels, Belgium)	toll-free: 080016884
	Corporate Sales (Brussels, Belgium)	02 481 91 00
	Customer Care (Brussels, Belgium)	02 481 91 19
	Fax (Brussels, Belgium)	02 481 92 99
Switchboard (Brussels, Belgium)	02 481 91 00	

Country (City) International Access Code Country Code City Code	Department Name or Service Area, Website and E-Mail Address	Area Codes, Local Numbers, and Toll-Free Numbers
Mexico International Access Code: 00 Country Code: 52	Customer Technical Support	001-877-384-8979
		or 001-877-269-3383
	Sales	50-81-8800
		or 01-800-888-3355
	Customer Service	001-877-384-8979
		or 001-877-269-3383
	Main	50-81-8800
		or 01-800-888-3355
Netherlands (Amsterdam)	Website: support.euro.dell.com	
International Access Code: 00	E-mail (Technical Support):	
Country Code: 31	(Enterprise): nl_server_support@dell.com	
City Code: 20	(Latitude): nl_latitude_support@dell.com	
	(Inspiron): nl_inspiron_support@dell.com	
	(Dimension): nl_dimension_support@dell.com	
	(OptiPlex): nl_optiplex_support@dell.com	
	(Dell Precision): nl_workstation_support@dell.com	
	Technical Support	020 674 45 00
	Technical Support Fax	020 674 47 66
	Home/Small Business Customer Care	020 674 42 00
	Relational Customer Care	020 674 4325
	Home/Small Business Sales	020 674 55 00
	Relational Sales	020 674 50 00
	Home/Small Business Sales Fax	020 674 47 75
	Relational Sales Fax	020 674 47 50
	Switchboard	020 674 50 00
	Switchboard Fax	020 674 47 50

Country (City) International Access Code Country Code City Code	Department Name or Service Area, Website and E-Mail Address	Area Codes, Local Numbers, and Toll-Free Numbers
Norway (Lysaker) International Access Code: 00 Country Code: 47	Website: support.euro.dell.com E-mail Support (portable computers): nor_nbk_support@dell.com E-mail Support (desktop computers): nor_support@dell.com E-mail Support (servers): nordic_server_support@dell.com	
	Technical Support	671 16882
	Relational Customer Care	671 17514
	Home/Small Business Customer Care	23162298
	Switchboard	671 16800
	Fax Switchboard	671 16865
Poland (Warsaw) International Access Code: 011 Country Code: 48 City Code: 22	Website: support.euro.dell.com E-mail: pl_support@dell.com	
	Customer Service Phone	57 95 700
	Customer Care	57 95 999
	Sales	57 95 999
	Customer Service Fax	57 95 806
	Reception Desk Fax	57 95 998
	Switchboard	57 95 999
Portugal International Access Code: 00 Country Code: 351	Website: support.euro.dell.com E-mail: support.euro.dell.com/pt/en/emailldell/	
	Technical Support	707200149
	Customer Care	800 300 413
	Sales	800 300 410 or 800 300 411 or 800 300 412 or 21 422 07 10
	Fax	21 424 01 12
Puerto Rico	General Support	1-800-805-7545

Country (City) International Access Code Country Code City Code	Department Name or Service Area, Website and E-Mail Address	Area Codes, Local Numbers, and Toll-Free Numbers
Singapore (Singapore)	Technical Support	toll-free: 800 6011 051
International Access Code: 005	Customer Service (Penang, Malaysia)	604 633 4949
Country Code: 65	Transaction Sales	toll-free: 800 6011 054
	Corporate Sales	toll-free: 800 6011 053
Spain (Madrid)	Website: support.euro.dell.com	
International Access Code: 00	E-mail: support.euro.dell.com/es/es/emaildell/	
Country Code: 34	Home and Small Business	
City Code: 91	Technical Support	902 100 130
	Customer Care	902 118 540
	Sales	902 118 541
	Switchboard	902 118 541
	Fax	902 118 539
	Corporate	
	Technical Support	902 100 130
	Customer Care	902 118 546
	Switchboard	91 722 92 00
	Fax	91 722 95 83
Sweden (Upplands Vasby)	Website: support.euro.dell.com	
International Access Code: 00	E-mail: swe_support@dell.com	
Country Code: 46	E-mail Support for Latitude and Inspiron: Swe-nbk_kats@dell.com	
City Code: 8	E-mail Support for OptiPlex: Swe_kats@dell.com	
	E-mail Support for Servers: Nordic_server_support@dell.com	
	Technical Support	08 590 05 199
	Relational Customer Care	08 590 05 642
	Home/Small Business Customer Care	08 587 70 527
	Employee Purchase Program (EPP) Support	20 140 14 44
	Fax Technical Support	08 590 05 594
	Sales	08 590 05 185

Country (City) International Access Code Country Code City Code	Department Name or Service Area, Website and E-Mail Address	Area Codes, Local Numbers, and Toll-Free Numbers
Switzerland (Geneva) International Access Code: 00 Country Code: 41 City Code: 22	Website: support.euro.dell.com E-mail: swisstech@dell.com E-mail for French-speaking HSB and Corporate Customers: support.euro.dell.com/ch/fr/emaildell/	
	Technical Support (Home and Small Business)	0844 811 411
	Technical Support (Corporate)	0844 822 844
	Customer Care (Home and Small Business)	0848 802 202
	Customer Care (Corporate)	0848 821 721
	Fax	022 799 01 90
	Switchboard	022 799 01 01
U.K. (Bracknell) International Access Code: 00 Country Code: 44 City Code: 1344	Website: support.euro.dell.com Customer Care website: support.euro.dell.com/uk/en/ECare/Form/Home.asp E-mail: dell_direct_support@dell.com	
	Technical Support (Corporate/Preferred Accounts/PAD [1000+ employees])	0870 908 0500
	Technical Support (direct/PAD and general)	0870 908 0800
	Global Accounts Customer Care	01344 373 186
	Home and Small Business Customer Care	0870 906 0010
	Corporate Customer Care	01344 373 185
	Preferred Accounts (500–5000 employees) Customer Care	0870 906 0010
	Central Government Customer Care	01344 373 193
	Local Government & Education Customer Care	01344 373 199
	Health Customer Care	01344 373 194
	Home and Small Business Sales	0870 907 4000
	Corporate/Public Sector Sales	01344 860 456

SECTION 7

Appendix

Limited Warranties and Return Policy

Dell Inc. Ink and Toner Cartridges Limited Warranties

Dell Software License Agreement

Regulatory Notices

Limited Warranties and Return Policy

Dell-branded hardware products purchased in the U.S. or Canada come with either a 90-day, one-year, two-year, three-year, or four-year limited warranty. To determine which warranty came with your hardware product(s), see your packing slip or invoice. The following sections describe the limited warranties and return policy for the U.S., the limited warranties and return policy for Canada, and the manufacturer guarantee for Latin America and the Caribbean.

Limited Warranty for Dell-Branded Hardware Products (U.S. Only)

What is covered by this limited warranty?

This limited warranty covers defects in materials and workmanship in your—our end-user customer's—Dell-branded hardware products, including Dell-branded peripheral products.

What is not covered by this limited warranty?

This limited warranty does not cover:

- Software, including the operating system and software added to the Dell-branded hardware products through our factory-integration system, third-party software, or the reloading of software
- Non-Dell-branded and Solution Provider Direct products and accessories
- Problems that result from:
 - External causes such as accident, abuse, misuse, or problems with electrical power
 - Servicing not authorized by Dell
 - Usage that is not in accordance with product instructions
 - Failure to follow the product instructions or failure to perform preventive maintenance
 - Problems caused by using accessories, parts, or components not supplied by Dell
- Products with missing or altered service tags or serial numbers
- Products for which we have not received payment

THIS WARRANTY GIVES YOU SPECIFIC LEGAL RIGHTS, AND YOU MAY ALSO HAVE OTHER RIGHTS WHICH VARY FROM STATE TO STATE (OR JURISDICTION TO JURISDICTION). DELL'S RESPONSIBILITY FOR MALFUNCTIONS AND DEFECTS IN HARDWARE IS LIMITED TO REPAIR AND REPLACEMENT AS SET FORTH IN THIS WARRANTY STATEMENT. ALL EXPRESS AND IMPLIED WARRANTIES FOR THE PRODUCT, INCLUDING BUT NOT LIMITED TO ANY IMPLIED WARRANTIES AND CONDITIONS OF MERCHANTABILITY AND FITNESS FOR A PARTICULAR PURPOSE, ARE LIMITED IN TIME TO THE TERM OF THE LIMITED WARRANTY PERIOD REFLECTED ON YOUR PACKING SLIP OR INVOICE. NO WARRANTIES, WHETHER EXPRESS OR IMPLIED, WILL APPLY AFTER THE LIMITED WARRANTY PERIOD HAS EXPIRED. SOME STATES DO NOT ALLOW LIMITATIONS ON HOW LONG AN IMPLIED WARRANTY LASTS, SO THIS LIMITATION MAY NOT APPLY TO YOU.

WE DO NOT ACCEPT LIABILITY BEYOND THE REMEDIES PROVIDED FOR IN THIS LIMITED WARRANTY OR FOR CONSEQUENTIAL OR INCIDENTAL DAMAGES, INCLUDING, WITHOUT LIMITATION, ANY LIABILITY FOR THIRD-PARTY CLAIMS AGAINST YOU FOR DAMAGES, FOR PRODUCTS NOT BEING AVAILABLE FOR USE, OR FOR LOST DATA OR LOST SOFTWARE. OUR LIABILITY WILL BE NO MORE THAN THE AMOUNT YOU PAID FOR THE PRODUCT THAT IS THE SUBJECT OF A CLAIM. THIS IS THE MAXIMUM AMOUNT FOR WHICH WE ARE RESPONSIBLE.

SOME STATES DO NOT ALLOW THE EXCLUSION OR LIMITATION OF INCIDENTAL OR CONSEQUENTIAL DAMAGES, SO THE ABOVE LIMITATION OR EXCLUSION MAY NOT APPLY TO YOU.

How long does this limited warranty last?

This limited warranty lasts for the time period indicated on your packing slip or invoice, except that the limited warranty on Dell-branded batteries lasts only one year and the limited warranty on the lamps for Dell-branded projectors lasts only ninety days. The limited warranty begins on the date of the packing slip or invoice. The warranty period is not extended if we repair or replace a warranted product or any parts. Dell may change the availability of limited warranties, at its discretion, but any changes will not be retroactive.

What do I do if I need warranty service?

Before the warranty expires, please call us at the relevant number listed in the following table. Please also have your Dell service tag number or order number available.

Individual Home Consumers:	U.S. Only
Technical Support	1-800-624-9896
Customer Service	1-800-624-9897
Individual Home Consumers who purchased through an Employee Purchase Program:	
Technical Support and Customer Service	1-800-822-8965
Home and Small Business Commercial Customers:	
Technical Support and Customer Service	1-800-456-3355
Medium, Large, or Global Commercial Customers, Healthcare Customers, and Value Added Resellers (VARs):	
Technical Support and Customer Service	1-877-459-7298
Government and Education Customers:	
Technical Support and Customer Service	1-877-459-7298
Dell-Branded Memory	1-888-363-5150

What will Dell do?

During the 90 days of the 90-day limited warranty and the first year of all other limited warranties: During the 90 days of the 90-day limited warranty and the first year of all other limited warranties, we will repair any Dell-branded hardware products returned to us that prove to be defective in materials or workmanship. If we are not able to repair the product, we will replace it with a comparable product that is new or refurbished.

When you contact us, we will issue a Return Material Authorization Number for you to include with your return. You must return the products to us in their original or equivalent packaging, prepay shipping charges, and insure the shipment or accept the risk if the product is lost or damaged in shipment. We will return the repaired or replacement products to you. We will pay to ship the repaired or replaced products to you if you use an address in the United States (excluding Puerto Rico and U.S. possessions and territories). Otherwise, we will ship the product to you freight collect.

If we determine that the product is not covered under this warranty, we will notify you and inform you of service alternatives that are available to you on a fee basis.

NOTE: Before you ship the product(s) to us, make sure to back up the data on the hard drive(s) and any other storage device(s) in the product(s). Remove any confidential, proprietary, or personal information and removable media such as floppy disks, CDs, or PC Cards. We are not responsible for any of your confidential, proprietary, or personal information; lost or corrupted data; or damaged or lost removable media.

During the remaining years: For the remaining period of the limited warranty, we will replace any defective part with new or refurbished parts, if we agree that it needs to be replaced. When you contact us, we will require a valid credit card number at the time you request a replacement part, but we will not charge you for the replacement part as long as you return the original part to us within thirty days after we ship the replacement part to you. If we do not receive the original part within thirty days, we will charge to your credit card the then-current standard price for that part.

We will pay to ship the part to you if you use an address in the United States (excluding Puerto Rico and U.S. possessions and territories). Otherwise, we will ship the part freight collect. We will also include a prepaid shipping container with each replacement part for your use in returning the replaced part to us.

NOTE: Before you replace parts, make sure to back up the data on the hard drive(s) and any other storage device(s) in the product(s). We are not responsible for lost or corrupted data.

What if I purchased a service contract?

If your service contract is with Dell, service will be provided to you under the terms of the service agreement. Please refer to that contract for details on how to obtain service.

If you purchased through us a service contract with one of our third-party service providers, please refer to that contract for details on how to obtain service.

How will you fix my product?

We use new and refurbished parts made by various manufacturers in performing warranty repairs and in building replacement parts and systems. Refurbished parts and systems are parts or systems that have been returned to Dell, some of which were never used by a customer. All parts and systems are inspected and tested for quality. Replacement parts and systems are covered for the remaining period of the limited warranty for the product you bought. Dell owns all parts removed from repaired products.

What do I do if I am not satisfied?

We pride ourselves on our great customer service. If you are not satisfied with the service you receive under this limited warranty, please let us know. We have found that the best way to resolve issues regarding our limited warranty is to work together. If, after those discussions, you are still not satisfied, we believe arbitration is the most expeditious way to resolve your concerns. Therefore, **ANY CLAIM, DISPUTE, OR CONTROVERSY (WHETHER IN CONTRACT, TORT, OR OTHERWISE, WHETHER PREEXISTING, PRESENT, OR FUTURE, AND INCLUDING STATUTORY, COMMON LAW, INTENTIONAL TORT, AND EQUITABLE CLAIMS) AGAINST DELL** arising from or relating to this limited warranty, its interpretation, or the breach, termination, or validity thereof, the relationships which result from this limited warranty (including, to the full extent permitted by applicable law, relationships with third parties), Dell's advertising, or any related purchase **SHALL BE RESOLVED EXCLUSIVELY AND FINALLY BY BINDING ARBITRATION ADMINISTERED BY THE NATIONAL ARBITRATION FORUM (NAF)** under its Code of Procedure then in effect (available via the Internet at www.arb-forum.com/ or via telephone at 1-800-474-2371). The arbitration will be limited solely to the dispute or controversy between you and Dell. Any award of the arbitrator(s) shall be final and binding on each of the parties, and may be entered as a judgment in any court of competent jurisdiction. Information may be obtained and claims may be filed with the NAF at P.O. Box 50191, Minneapolis, MN 55405. This provision applies only to individual home consumers and consumers who purchased through an employee purchase program. It does not apply to small, medium, large, and global commercial customers or government, education, and healthcare customers.

May I transfer the limited warranty?

Limited warranties on systems may be transferred if the current owner transfers ownership of the system and records the transfer with us. The limited warranty on Dell-branded memory may not be transferred. You may record your transfer by going to Dell's website:

- If you are an Individual Home Consumer, go to www.dell.com/us/en/dhs/topics/sbtopic_015_ccare.htm
- If you are a Home Office, Small, Medium, Large, or Global Commercial Customer, go to www.dell.com/us/en/biz/topics/sbtopic_ccare_nav_015_ccare.htm
- If you are a Government, Education, or Healthcare Customer, or an Individual Home Consumer who purchased through an employee purchase program, go to www.dell.com/us/en/pub/topics/sbtopic_015_ccare.htm

If you do not have Internet access, call your customer care representative or call 1-800-624-9897.

"Total Satisfaction" Return Policy (U.S. Only)

We value our relationship with you and want to make sure that you're satisfied with your purchases. That's why we offer a "Total Satisfaction" return policy for most products that you—the end-user customer—purchase directly from Dell. Under this policy, you may return to Dell products that you purchased directly from Dell for a credit or a refund of the purchase price paid, less shipping and handling and applicable restocking fees as follows:

- **New Hardware Products and Accessories** — All new hardware, accessories, parts, and unopened software still in its sealed package, excluding the products listed below, may be returned within thirty days from the date on the packing slip or invoice. To return applications software or an operating system that has been installed by Dell, you must return the entire computer. A different return policy applies to nondefective products purchased through Dell's Software and Peripherals division by customers of our Small and Medium Business divisions. Those products may be returned within thirty days from the date on the packing slip or invoice, but a fifteen percent (15%) restocking fee will be deducted from any refund or credit. The "Total Satisfaction" Return Policy and Software and Peripherals division return policy are not available for Dell | EMC storage products, EMC-branded products, or enterprise software.

- **Reconditioned or Refurbished Dell-Branded Hardware Products and Parts** — All reconditioned or refurbished Dell-branded server and storage products may be returned within thirty days from the date on the packing slip or invoice. All other reconditioned or refurbished Dell-branded hardware products and parts may be returned within fourteen days of the date on the packing slip or invoice.

To return products, e-mail or call Dell customer service to receive a Credit Return Authorization Number within the return policy period applicable to the product you want to return. You must obtain a Credit Return Authorization Number in order to return the product. See "Contacting Dell" or "Getting Help" in your customer documentation (or www.dell.com/us/en/gen/contact.htm) to find the appropriate contact information for obtaining customer assistance.

You must ship the products to Dell within five days of the date that Dell issues the Credit Return Authorization Number. You must also return the products to Dell in their original packaging, in as-new condition along with any media, documentation, and all other items that were included in the original shipment, prepay shipping charges, and insure the shipment or accept the risk of loss or damage during shipment.

Limited Warranty Terms for Dell-Branded Hardware Products (Canada Only)

What is covered by this limited warranty?

This limited warranty covers defects in materials and workmanship in your—our end-user customer's—Dell-branded hardware products, including Dell-branded peripheral products.

What is not covered by this limited warranty?

This limited warranty does not cover:

- Software, including the operating system and software added to the Dell-branded hardware products through our factory-integration system, or the reloading of the software
- Non-Dell branded and Solution Provider Direct products and accessories
- Problems that result from:
 - External causes such as accident, abuse, misuse, or problems with electrical power
 - Servicing not authorized by Dell
 - Usage that is not in accordance with product instructions
 - Failure to follow the product instructions or failure to perform preventive maintenance
 - Problems caused by using accessories, parts, or components not supplied by Dell
- Products with missing or altered service tags or serial numbers
- Products for which we have not received payment

THIS WARRANTY GIVES YOU SPECIFIC LEGAL RIGHTS, AND YOU MAY ALSO HAVE OTHER RIGHTS WHICH VARY FROM PROVINCE TO PROVINCE. DELL'S RESPONSIBILITY FOR MALFUNCTIONS AND DEFECTS IN PRODUCT IS LIMITED TO REPAIR AND REPLACEMENT AS SET FORTH IN THIS WARRANTY STATEMENT, FOR THE TERM OF THE WARRANTY PERIOD REFLECTED ON YOUR PACKING SLIP OR INVOICE. EXCEPT FOR THE EXPRESS WARRANTIES CONTAINED IN THIS WARRANTY STATEMENT, DELL DISCLAIMS ALL OTHER WARRANTIES AND CONDITIONS, EXPRESS OR IMPLIED, INCLUDING WITHOUT LIMITATION IMPLIED WARRANTIES AND CONDITIONS OF MERCHANTABILITY AND FITNESS FOR A PARTICULAR PURPOSE, STATUTORY OR OTHERWISE. SOME PROVINCES DO NOT ALLOW THE EXCLUSION OF CERTAIN IMPLIED WARRANTIES OR CONDITIONS, OR LIMITATIONS ON HOW LONG AN IMPLIED WARRANTY OR CONDITION LASTS. THEREFORE, THE FOREGOING EXCLUSIONS AND LIMITATIONS MAY NOT APPLY TO YOU.

WE DO NOT ACCEPT LIABILITY BEYOND THE REMEDIES PROVIDED FOR IN THIS WARRANTY STATEMENT OR FOR SPECIAL, INDIRECT, CONSEQUENTIAL, OR INCIDENTAL DAMAGES, INCLUDING, WITHOUT LIMITATION, ANY LIABILITY FOR THIRD-PARTY CLAIMS AGAINST YOU FOR DAMAGES, FOR PRODUCTS NOT BEING AVAILABLE FOR USE, OR FOR LOST DATA OR LOST SOFTWARE. OUR LIABILITY WILL BE NO MORE THAN THE AMOUNT YOU PAID FOR THE PRODUCT THAT IS THE SUBJECT OF A CLAIM. THIS IS THE MAXIMUM AMOUNT FOR WHICH WE ARE RESPONSIBLE.

SOME PROVINCES DO NOT ALLOW THE EXCLUSION OR LIMITATION OF SPECIAL, INDIRECT, INCIDENTAL, OR CONSEQUENTIAL DAMAGES, SO THE ABOVE LIMITATION OR EXCLUSION MAY NOT APPLY TO YOU.

How long does this limited warranty last?

This limited warranty lasts for the time period indicated on your packing slip or invoice, except that the limited warranty on Dell-branded batteries lasts only one year and the limited warranty on the lamps for Dell-branded projectors lasts only ninety days. The limited warranty begins on the date of the packing slip or invoice. The warranty period is not extended if we repair or replace a warranted product or any parts. Dell may change the terms and availability of limited warranties, at its discretion, but any changes will not be retroactive (that is, the warranty terms in place at the time of purchase will apply to your purchase).

What do I do if I need warranty service?

Before the warranty expires, please call us at the relevant number listed in the following table. Please also have your Dell service tag number or order number available.

Individual Home Consumers; Home Office and Small Business Customers:	Canada Only
Technical Support and Customer Service	1-800-847-4096
Medium, Large, and Global Commercial Customers; Government, Education, and Healthcare Customers; and Value Added Resellers (VARs):	
Technical Support	1-800-387-5757
Customer Service	1-800-326-9463
Government or Education Customers, or Individual Home Consumers who purchased through an Employee Purchase Program:	
Technical Support	1-800-387-5757
Customer Service	1-800-326-9463 (Extension 8221 for Individual Consumers)
Dell-Branded Memory	1-888-363-5150

What will Dell do?

During the 90 days of the 90-day limited warranty and the first year of all other limited warranties: During the 90 days of the 90-day limited warranty and the first year of all other limited warranties, we will repair any Dell-branded hardware products returned to us that prove to be defective in materials or workmanship. If we are not able to repair the product, we will replace it with a comparable product that is new or refurbished.

When you contact us, we will issue a Return Material Authorization Number for you to include with your return. You must return the products to us in their original or equivalent packaging, prepay shipping charges, and insure the shipment or accept the risk if the product is lost or damaged in shipment. We will return the repaired or replacement products to you. We will pay to ship the repaired or replaced products to you if you use an address in Canada. Otherwise, we will ship the product to you freight collect.

If we determine that the problem is not covered under this warranty, we will notify you and inform you of service alternatives that are available to you on a fee basis.

NOTE: Before you ship the product(s) to us, make sure to back up the data on the hard drive(s) and any other storage device(s) in the product(s). Remove any confidential, proprietary or personal information, removable media, such as floppy disks, CDs, or PC Cards. We are not responsible for any of your confidential, proprietary or personal information; lost or corrupted data; or damaged or lost removable media.

During the remaining years following the first year of all limited warranties: We will replace any defective part with new or refurbished parts, if we agree that it needs to be replaced. When you contact us, we will require a valid credit card number at the time you request a replacement part, but we will not charge you for the replacement part as long as you return the original part to us within thirty days after we ship the replacement part to you. If we do not receive the original part within thirty days, we will charge to your credit card the then-current standard price for that part.

We will pay to ship the part to you if you use an address in Canada. Otherwise, we will ship the part freight collect. We will also include a prepaid shipping container with each replacement part for your use in returning the replaced part to us.

NOTE: Before you replace parts, make sure to back up the data on the hard drive(s) and any other storage device(s) in the product(s). We are not responsible for lost or corrupted data.

What if I purchased a service contract?

If your service contract is with Dell, service will be provided to you under the terms of the service contract. Please refer to that contract for details on how to obtain service. Dell's service contracts can be found online at www.dell.ca or by calling Customer Care at 1-800-847-4096. If you purchased through us a service contract with one of our third-party service providers, please refer to that contract (mailed to you with your packing slip or invoice) for details on how to obtain service.

How will you fix my product?

We use new and refurbished parts made by various manufacturers in performing warranty repairs and in building replacement parts and systems. Refurbished parts and systems are parts or systems that have been returned to Dell, some of which were never used by a customer. All parts and systems are inspected and tested for quality. Replacement parts and systems are covered for the remaining period of the limited warranty for the product you bought. Dell owns all parts removed from repaired products.

What do I do if I am not satisfied?

We pride ourselves on our great customer service. If you are not satisfied with the service you receive under this limited warranty, please let us know. We have found that the best way to resolve issues regarding our limited warranty is to work together. If, after those discussions, you are still not satisfied, we believe arbitration is the most expeditious way to resolve your concerns. Therefore, **ANY CLAIM, DISPUTE, OR CONTROVERSY (WHETHER IN CONTRACT, TORT, OR OTHERWISE, WHETHER PREEXISTING, PRESENT OR FUTURE, AND INCLUDING STATUTORY, COMMON LAW, INTENTIONAL TORT, AND EQUITABLE CLAIMS) AGAINST DELL** arising from or relating to this limited warranty, its interpretation, or the breach, termination or validity thereof, the relationships which result from this limited warranty (including, to the full extent permitted by applicable law, relationships with third parties), Dell's advertising, or any related purchase **SHALL BE RESOLVED EXCLUSIVELY AND FINALLY BY BINDING ARBITRATION ADMINISTERED BY THE NATIONAL ARBITRATION FORUM (NAF)** under its Code of Procedure then in effect (available via the Internet at www.arb-forum.com/, or via telephone at 1-800-474-2371). The arbitration will be limited solely to the dispute or controversy between you and Dell. Any award of the arbitrator(s) shall be final and binding on each of the parties, and may be entered as a judgment in any court of competent jurisdiction. Information may be obtained and claims may be filed with the NAF at P.O. Box 50191, Minneapolis, MN 55405.

May I transfer the limited warranty?

Limited warranties on systems may be transferred if the current owner transfers ownership of the system and records the transfer with us. The limited warranty on Dell-branded memory may not be transferred. You may record your transfer by going to Dell's website:

- For Canada-purchased computers (in-country transfers) and to transfer from one customer to another, go to www.dell.ca/ca/en/gen/topics/segtopic_ccare_nav_013_ccare.htm
- For out-of-country transfers (outside of the original country of purchase), go to www.dell.com/us/en/biz/topics/sbtopic_ccare_nav_016_ccare.htm

If you do not have Internet access, call Dell at 1-800-847-4096 (Home Consumer customers) or 1-800-326-9463 (Corporate Commercial or Government customers).

"Total Satisfaction" Return Policy (Canada Only)

If you are an end-user customer who bought new products directly from Dell, you may return them to Dell up to 30 days after you receive them for a refund or credit of the product purchase price. If you are an end-user customer who bought reconditioned or refurbished products from Dell, you may return them to Dell within 14 days after the date on the packing slip or invoice for a refund or credit of the product purchase price. In either case, the refund or credit will not include any shipping and handling charges shown on your packing slip or invoice and will be subject to a fifteen percent (15%) restocking fee, unless otherwise prohibited by law. If you are an organization that bought the products under a written agreement with Dell, the agreement may contain different terms for the return of products than specified by this policy.

To return products, you must call Dell Customer Service at 1-800-847-4096 to receive a Credit Return Authorization Number. To expedite the process of your refund or credit, Dell expects you to return the products to Dell in their original packaging within five days of the date that Dell issues the Credit Return Authorization Number. You must also prepay shipping charges and insure the shipment or accept the risk of loss or damage during shipment. You may return software for a refund or credit only if the sealed package containing the floppy disk(s) or CD(s) is unopened. Returned products must be in as-new condition, and all of the manuals, floppy disk(s), CD(s), power cables, and other items included with a product must be returned with it. For customers who want to return, for refund or credit only, either application or operating system software that has been installed by Dell, the whole system must be returned, along with any media and documentation that may have been included in the original shipment.

The "Total Satisfaction" Return Policy does not apply to Dell | EMC storage products. It also does not apply to products purchased through Dell's Software and Peripherals division. For those products, please instead refer to Dell's Software and Peripheral's then-current return policy (see the following section, "Dell Software and Peripherals (Canada Only)").

Dell Software and Peripherals (Canada Only)

Third-Party Software and Peripherals Products

Similar to other resellers of software and peripherals, Dell does not warrant third-party products. Third-party software and peripheral products are covered by the warranties provided by the original manufacturer or publisher only. Third-party manufacturer warranties vary from product to product. Consult your product documentation for specific warranty information. More information may also be available from the manufacturer or publisher.

While Dell offers a wide selection of software and peripheral products, we do not specifically test or guarantee that all of the products we offer work with any or all of the various models of Dell computers, nor do we test or guarantee all of the products we sell on the hundreds of different brands of computers available today. If you have questions about compatibility, we recommend and encourage you to contact the third-party software and peripheral product manufacturer or publisher directly.

Dell-Branded Peripheral Products

Dell does provide a limited warranty for new Dell-branded peripheral products (products for which Dell is listed as the manufacturer) such as monitors, batteries, memory, docking stations, and projectors). To determine which limited warranty applies to the product you purchased, see the Dell packing slip or invoice and/or the product documentation that accompanied your product. Descriptions of Dell's limited warranties are described in preceding sections.

Return Policy

If you are an end-user customer who bought Dell Software and Peripherals products directly from a Dell company, you may return Dell Software and Peripherals products that are in as-new condition to Dell up to 30 days from the date on the packing slip or invoice for a refund of the product purchase price if already paid. This refund will not include any shipping and handling charges shown on your packing slip or invoice; you are responsible for those.

To return products, you must call Dell Customer Service at 1-800-387-5759 to receive a Credit Return Authorization Number. You must ship the Dell Software and Peripherals products back to Dell in their original manufacturer's packaging (which must be in as-new condition), prepay shipping charges, and insure the shipment or accept the risk of loss or damage during shipment.

To qualify for refund or replacement, returned products must be in as-new condition, software products must be unopened, and all of the manuals, floppy disk(s), CD(s), power cables, and other items included with a product must be returned with it.

One-Year End-User Manufacturer Guarantee (Latin America and the Caribbean Only)

Guarantee

Dell Inc. ("Dell") warrants to the end user in accordance with the following provisions that its branded hardware products, purchased by the end user from a Dell company or an authorized Dell distributor in Latin America or the Caribbean, will be free from defects in materials, workmanship, and design affecting normal use, for a period of one year from the original purchase date. Products for which proper claims are made will, at Dell's option, be repaired or replaced at Dell's expense. Dell owns all parts removed from repaired products. Dell uses new and reconditioned parts made by various manufacturers in performing repairs and building replacement products.

Exclusions

This Guarantee does not apply to defects resulting from: improper or inadequate installation, use, or maintenance; actions or modifications by unauthorized third parties or the end user; accidental or willful damage; or normal wear and tear.

Making a Claim

Claims must be made in Latin America or the Caribbean by contacting the Dell point of sale within the guarantee period. The end user must always supply proof of purchase, indicating name and address of the seller, date of purchase, model and serial number, name and address of the customer, and details of symptoms and configuration at the time of malfunction, including peripherals and software used. Otherwise, Dell may refuse the guarantee claim. Upon diagnosis of a warranted defect, Dell will make arrangements and pay for ground freight and insurance to and from Dell's repair/replacement center. The end user must ensure that the defective product is available for collection properly packed in original or equally protective packaging together with the details listed above and the return number provided to the end user by Dell.

Limitation and Statutory Rights

Dell makes no other warranty, guarantee or like statement other than as explicitly stated above, and this Guarantee is given in place of all other guarantees whatsoever, to the fullest extent permitted by law. In the absence of applicable legislation, this Guarantee will be the end user's sole and exclusive remedy against Dell or any of its affiliates, and neither Dell nor any of its affiliates shall be liable for loss of profit or contracts, or any other indirect or consequential loss arising from negligence, breach of contract, or howsoever.

This Guarantee does not impair or affect mandatory statutory rights of the end user against and/or any rights resulting from other contracts concluded by the end user with Dell and/or any other seller.

Dell World Trade LP

One Dell Way, Round Rock, TX 78682, USA

Dell Computadores do Brasil Ltda (CNPJ No. 72.381.189/0001-10)/

Dell Commercial do Brasil Ltda (CNPJ No. 03 405 822/0001-40)

Avenida Industrial Belgraf, 400

92990-000 - Eldorado do Sul – RS - Brasil

Dell Computer de Chile Ltda

Coyancura 2283, Piso 3- Of.302,

Providencia, Santiago - Chile

Dell Computer de Colombia Corporation

Carrera 7 #115-33 Oficina 603

Bogota, Colombia

Dell Computer de Mexico SA de CV

Paseo de la Reforma 2620 - 11° Piso

Col. Lomas Altas

11950 México, D.F.

Dell Inc.

Ink and Toner Cartridges Limited Warranties

The following sections describe the limited warranty for ink and toner cartridges for the U.S., Canada, and Latin America. Refer to the appropriate limited warranty accordingly.

Ink and Toner Cartridges Limited Warranty (U.S. and Canada Only)

Dell Inc. warrants to the original purchaser of genuine Dell-branded toner cartridges that they will be free from defects in material and workmanship for the life of the cartridge and that for genuine Dell-branded ink cartridges they will be free from defects in material and workmanship for two years beginning on the date of invoice. If this product proves defective in either material or workmanship, it will be replaced without charge during the limited warranty period if returned to Dell. You must first call our toll-free number to get your return authorization. In the U.S., call 1-800-822-8965; in Canada, call 1-800-387-5757. If we are not able to replace the product because it has been discontinued or is not available, we will either replace it with a comparable product or reimburse you for the cartridge purchase cost, at Dell's sole option. This limited warranty does not apply to ink or toner cartridges that have been refilled or improperly stored or due to problems resulting from misuse, abuse, accident, neglect, mishandling, incorrect environments, or wear from ordinary use.

THIS WARRANTY GIVES YOU SPECIFIC LEGAL RIGHTS, AND YOU MAY ALSO HAVE OTHER RIGHTS WHICH VARY FROM STATE TO STATE (OR JURISDICTION TO JURISDICTION). DELL'S RESPONSIBILITY FOR MALFUNCTIONS AND DEFECTS IN HARDWARE IS LIMITED TO REPLACEMENT AS SET FORTH IN THIS WARRANTY STATEMENT. FOR CANADIAN CUSTOMERS, EXCEPT FOR THE EXPRESS WARRANTIES CONTAINED IN THIS WARRANTY STATEMENT, DELL DISCLAIMS ALL OTHER WARRANTIES AND CONDITIONS, EXPRESS OR IMPLIED, STATUTORY OR OTHERWISE, FOR THE PRODUCT. FOR U.S. CUSTOMERS, ALL EXPRESS AND IMPLIED WARRANTIES FOR THE PRODUCT, INCLUDING BUT NOT LIMITED TO ANY IMPLIED WARRANTIES AND CONDITIONS OF MERCHANTABILITY AND FITNESS FOR A PARTICULAR PURPOSE ARE LIMITED IN TIME TO THE TERM OF THIS LIMITED WARRANTY. NO WARRANTIES, WHETHER EXPRESS OR IMPLIED, WILL APPLY AFTER THE LIMITED WARRANTY PERIOD HAS EXPIRED. SOME STATES OR JURISDICTIONS DO NOT ALLOW THE EXCLUSION OF CERTAIN IMPLIED WARRANTIES OR CONDITIONS, OR LIMITATIONS ON HOW LONG AN IMPLIED WARRANTY OR CONDITION LASTS, SO THIS LIMITATION MAY NOT APPLY TO YOU. THIS WARRANTY COVERAGE TERMINATES IF YOU SELL OR OTHERWISE TRANSFER THIS PRODUCT TO ANOTHER PARTY.

DELL DOES NOT ACCEPT LIABILITY BEYOND THE REMEDIES PROVIDED FOR IN THIS LIMITED WARRANTY OR FOR SPECIAL, INDIRECT, CONSEQUENTIAL OR INCIDENTAL DAMAGES, INCLUDING, WITHOUT LIMITATION, ANY LIABILITY FOR THIRD-PARTY CLAIMS AGAINST YOU FOR DAMAGES, FOR PRODUCTS NOT BEING AVAILABLE FOR USE, OR FOR LOST DATA OR LOST SOFTWARE. DELL'S LIABILITY WILL BE NO MORE THAN THE AMOUNT YOU PAID FOR THE PRODUCT THAT IS THE SUBJECT OF A CLAIM. THIS IS THE MAXIMUM AMOUNT FOR WHICH DELL IS RESPONSIBLE.

SOME STATES OR JURISDICTIONS DO NOT ALLOW THE EXCLUSION OR LIMITATION OF SPECIAL, INDIRECT, INCIDENTAL OR CONSEQUENTIAL DAMAGES, SO THE ABOVE LIMITATION OR EXCLUSION MAY NOT APPLY TO YOU.

Ink and Toner Cartridges Limited Warranty (Latin America Only)

Dell Inc. warrants to the original purchaser of genuine Dell-branded toner cartridges that the cartridges will be free from defects resulting from material or manufacturing process for the life of the cartridge. For the original purchaser of genuine Dell-branded ink cartridges, Dell warrants that the cartridges will be free from defects resulting from material or manufacturing process for one year beginning from the date of delivery.

If this product presents defects resulting from either material or manufacturing process, it will be replaced without charge during the limited warranty period if returned to Dell.

In order to obtain the necessary information to enable the replacement, call the appropriate toll-free number. In Mexico, call 001-877-533-6230; in Puerto Rico, call 1-877-839-5123. In cases in which either the production of the cartridge has been discontinued or the cartridge is not available, Dell reserves the right, at its sole discretion, to choose between replacing it by a similar product or reimbursing you for the purchase cost.

This limited warranty does not apply to ink or toner cartridges that have been refilled or to defects resulting from misuse, abuse, accident, negligence, mishandling, improper storage or exposure to inappropriate environments.

Dell's liability for the malfunction or defect of hardware after the period of the legal warranty (and specifically the period of the legal warranty of defective products stated in the consumer protections rules), is limited to either the substitution of the product or the reimbursement as stated above. This warranty coverage terminates if you sell or otherwise transfer this product to a third party.

Dell does not accept any additional liability for patrimonial, emotional or any other kind of damage caused to the consumer and/or to a third party, which exceeds the established liability either in this limited warranty or in legal rules that may apply.

Dell Software License Agreement

This is a legal agreement between you, the user, and Dell Products, L.P. ("Dell"). This agreement covers all software that is distributed with the Dell product, for which there is no separate license agreement between you and the manufacturer or owner of the software (collectively the "Software"). By opening or breaking the seal on the Software packet(s), installing or downloading the Software, or using the Software that has been preloaded or is embedded in your computer, you agree to be bound by the terms of this agreement. If you do not agree to these terms, promptly return all Software items (disks, written materials, and packaging) and delete any preloaded or embedded Software.

You may use one copy of the Software on only one computer at a time. If you have multiple licenses for the Software, you may use as many copies at any time as you have licenses. "Use" means loading the Software in temporary memory or permanent storage on the computer. Installation on a network server solely for distribution to other computers is not "use" if (but only if) you have a separate license for each computer to which the Software is distributed. You must ensure that the number of persons using the Software installed on a network server does not exceed the number of licenses that you have. If the number of users of Software installed on a network server will exceed the number of licenses, you must purchase additional licenses until the number of licenses equals the number of users before allowing additional users to use the Software. If you are a commercial customer of Dell or a Dell affiliate, you hereby grant Dell, or an agent selected by Dell, the right to perform an audit of your use of the Software during normal business hours, you agree to cooperate with Dell in such audit, and you agree to provide Dell with all records reasonably related to your use of the Software. The audit will be limited to verification of your compliance with the terms of this agreement.

The Software is protected by United States copyright laws and international treaties. You may make one copy of the Software solely for backup or archival purposes or transfer it to a single hard disk provided you keep the original solely for backup or archival purposes. You may not rent or lease the Software or copy the written materials accompanying the Software, but you may transfer the Software and all accompanying materials on a permanent basis if you retain no copies and the recipient agrees to the terms hereof. Any transfer must include the most recent update and all prior versions. You may not reverse engineer, decompile or disassemble the Software. If the package accompanying your computer contains compact discs, 3.5" and/or 5.25" disks, you may use only the disks appropriate for your computer. You may not use the disks on another computer or network, or loan, rent, lease, or transfer them to another user except as permitted by this agreement.

Limited Warranty

Dell warrants that the Software disks will be free from defects in materials and workmanship under normal use for ninety (90) days from the date you receive them. This warranty is limited to you and is not transferable. Any implied warranties are limited to ninety (90) days from the date you receive the Software. Some jurisdictions do not allow limits on the duration of an implied warranty, so this limitation may not apply to you. The entire liability of Dell and its suppliers, and your exclusive remedy, shall be (a) return of the price paid for the Software or (b) replacement of any disk not meeting this warranty that is sent with a return authorization number to Dell, at your cost and risk. This limited warranty is void if any disk damage has resulted from accident, abuse, misapplication, or service or modification by someone other than Dell. Any replacement disk is warranted for the remaining original warranty period or thirty (30) days, whichever is longer.

Dell does NOT warrant that the functions of the Software will meet your requirements or that operation of the Software will be uninterrupted or error free. You assume responsibility for selecting the Software to achieve your intended results and for the use and results obtained from the Software.

DELL, ON BEHALF OF ITSELF AND ITS SUPPLIERS, DISCLAIMS ALL OTHER WARRANTIES, EXPRESS OR IMPLIED, INCLUDING, BUT NOT LIMITED TO, IMPLIED WARRANTIES OF MERCHANTABILITY AND FITNESS FOR A PARTICULAR PURPOSE, FOR THE SOFTWARE AND ALL ACCOMPANYING WRITTEN MATERIALS. This limited warranty gives you specific legal rights; you may have others, which vary from jurisdiction to jurisdiction.

IN NO EVENT SHALL DELL OR ITS SUPPLIERS BE LIABLE FOR ANY DAMAGES WHATSOEVER (INCLUDING, WITHOUT LIMITATION, DAMAGES FOR LOSS OF BUSINESS PROFITS, BUSINESS INTERRUPTION, LOSS OF BUSINESS INFORMATION, OR OTHER PECUNIARY LOSS) ARISING OUT OF USE OR INABILITY TO USE THE SOFTWARE, EVEN IF ADVISED OF THE POSSIBILITY OF SUCH DAMAGES. Because some jurisdictions do not allow an exclusion or limitation of liability for consequential or incidental damages, the above limitation may not apply to you.

U.S. Government Restricted Rights

The software and documentation are "commercial items" as that term is defined at 48 C.F.R. 2.101, consisting of "commercial computer software" and "commercial computer software documentation" as such terms are used in 48 C.F.R. 12.212. Consistent with 48 C.F.R. 12.212 and 48 C.F.R. 227.7202-1 through 227.7202-4, all U.S. Government end users acquire the software and documentation with only those rights set forth herein. Contractor/manufacturer is Dell Products, L.P., One Dell Way, Round Rock, Texas 78682.

General

This license is effective until terminated. It will terminate upon the conditions set forth above or if you fail to comply with any of its terms. Upon termination, you agree that the Software and accompanying materials, and all copies thereof, will be destroyed. This agreement is governed by the laws of the State of Texas. Each provision of this agreement is severable. If a provision is found to be unenforceable, this finding does not affect the enforceability of the remaining provisions, terms, or conditions of this agreement. This agreement is binding on successors and assigns. Dell agrees and you agree to waive, to the maximum extent permitted by law, any right to a jury trial with respect to the Software or this agreement. Because this waiver may not be effective in some jurisdictions, this waiver may not apply to you. You acknowledge that you have read this agreement, that you understand it, that you agree to be bound by its terms, and that this is the complete and exclusive statement of the agreement between you and Dell regarding the Software.

Regulatory Notices

Electromagnetic Interference (EMI) is any signal or emission, radiated in free space or conducted along power or signal leads, that endangers the functioning of a radio navigation or other safety service or seriously degrades, obstructs, or repeatedly interrupts a licensed radio communications service. Radio communications services include but are not limited to AM/FM commercial broadcast, television, cellular services, radar, air-traffic control, pager, and Personal Communication Services (PCS). These licensed services, along with unintentional radiators such as digital devices, including computers, contribute to the electromagnetic environment.

Electromagnetic Compatibility (EMC) is the ability of items of electronic equipment to function properly together in the electronic environment. While this computer has been designed and determined to be compliant with regulatory agency limits for EMI, there is no guarantee that interference will not occur in a particular installation. If this equipment does cause interference with radio communications services, which can be determined by turning the equipment off and on, you are encouraged to try to correct the interference by one or more of the following measures:

- Reorient the receiving antenna.
- Relocate the computer with respect to the receiver.
- Move the computer away from the receiver.

- Plug the computer into a different outlet so that the computer and the receiver are on different branch circuits.

If necessary, consult a Dell Technical Support representative or an experienced radio/television technician for additional suggestions.

FCC Notices (U.S. Only)

Most Dell computers are classified by the Federal Communications Commission (FCC) as Class B digital devices. To determine which classification applies to your computer, examine all FCC registration labels located on the bottom, side, or back panel of your computer, on card-mounting brackets, and on the cards themselves. If any one of the labels carries a Class A rating, your entire computer is considered to be a Class A digital device. If *all* labels carry an FCC Class B rating as distinguished by either an FCC ID number or the FCC logo, (FC), your computer is considered to be a Class B digital device.

Once you have determined your computer's FCC classification, read the appropriate FCC notice. Note that FCC regulations provide that changes or modifications not expressly approved by Dell could void your authority to operate this equipment.

This device complies with Part 15 of the FCC Rules. Operation is subject to the following two conditions:

- This device may not cause harmful interference.
- This device must accept any interference received, including interference that may cause undesired operation.

Class B

This equipment has been tested and found to comply with the limits for a Class B digital device pursuant to Part 15 of the FCC Rules. These limits are designed to provide reasonable protection against harmful interference in a residential installation. This equipment generates, uses, and can radiate radio frequency energy and, if not installed and used in accordance with the manufacturer's instruction manual, may cause interference with radio communications. However, there is no guarantee that interference will not occur in a particular installation. If this equipment does cause harmful interference to radio or television reception, which can be determined by turning the equipment off and on, you are encouraged to try to correct the interference by one or more of the following measures:

- Reorient or relocate the receiving antenna.
- Increase the separation between the equipment and the receiver.
- Connect the equipment into an outlet on a circuit different from that to which the receiver is connected.
- Consult the dealer or an experienced radio/television technician for help.

FCC Identification Information

The following information is provided on the device or devices covered in this document in compliance with FCC regulations:

- Model number:

- Company name:
Dell Inc.
One Dell Way
Round Rock, Texas 78682 USA
512-338-4400

Modem Regulatory Information

This equipment complies with Part 68 of the FCC Rules. On the bottom of your computer is a label that contains, among other information, the FCC registration number and ringer equivalence number (REN) for your equipment. If requested, you must provide this information to the telephone company.

The REN is used to determine the quantity of devices that may be connected to the telephone line. Excessive RENs on the telephone line may result in the devices not ringing in response to an incoming call. In most areas, the sum of all the RENs on your telephone line should be less than five to ensure proper service from the telephone company. To be certain of the number of devices that you may connect to a line, as determined by the total RENs, contact your local telephone company.

The registration jack Universal Service Order Code (USOC) used by this equipment is RJ-11C. An FCC compliant telephone cord and modular plug is provided with this equipment. This equipment is designed to be connected to the telephone network or premises wiring using a compatible modular jack that is Part 68 compliant.

This equipment cannot be used on public coin-phone service provided by the telephone company. Connection to party line service is subject to state tariffs.

There are no user serviceable parts on the modem contained in your computer.

If your telephone equipment causes harm to the telephone network, the telephone company will notify you in advance that service may be temporarily discontinued. If advance notice is not practical, the telephone company will notify you as soon as possible. Also, you will be advised of your right to file a complaint with the FCC if you believe it is necessary.

The telephone company may make changes in its facilities, equipment, operations, or procedures that could affect the operation of this equipment. If this happens, the telephone company will provide advance notice in order for you to make necessary modifications to maintain uninterrupted service.

If you experience trouble with this telephone equipment, see "Getting Help" in your computer's troubleshooting documentation or, for some computers, the section titled "Contacting Dell" in your computer's online guide to find the appropriate telephone number for obtaining customer assistance. If the equipment is causing harm to the telephone network, the telephone company may request that you disconnect the equipment until the problem is resolved.

Fax Branding

The Telephone Consumer Protection Act of 1991 makes it unlawful for any person to use a computer or other electronic device, including fax machines, to send any message unless such message clearly contains in a margin at the top or bottom of each transmitted page or on the first page of the transmission, the date and time it is sent, identification of the business, other entity, or individual sending the message, and the telephone number of the sending machine or such business, other entity, or individual. The telephone number provided may not be a 900 number or any other number for which charges exceed local or long-distance transmission charges.

NOM Information (Mexico Only)

The following information is provided on the device(s) described in this document in compliance with the requirements of the official Mexican standards (NOM):

Exporter:	Dell Inc. One Dell Way Round Rock, TX 78682
Importer:	Dell Computer de México, S.A. de C.V. Paseo de la Reforma 2620 - 11° Piso Col. Lomas Altas 11950 México, D.F.
Ship to:	Dell Computer de México, S.A. de C.V. al Cuidado de Kuehne & Nagel de México S. de R.L. Avenida Soles No. 55 Col. Peñon de los Baños 15520 México, D.F.
Model number:	
Supply voltage:	100/240 VAC
Frequency:	50/60 Hz
Current Consumption:	1.5 A
Output voltage:	20 VDC
Output current:	3.5 A

Index

A

- aligning ink cartridges, 65
- All-In-One Center
 - using, 56
- All-In-One Main page
 - Copy section, 57
 - Preview section, 58
 - Productivity Tools section, 58
 - Scan section, 57

B

- banner paper, 27
- banners, printing, 59
- Black (Start) button, 16
- black and white, printing
 - in, 59
- blinking lights, 80
- both sides, printing on, *see* duplexing
- buttons, operator panel
 - , 16
 - +, 16
 - Black, 16
 - Color, 16
 - Copy, 15
 - Fax, 15
 - Lighter/Darker, 16
 - Number of Copies, 15

- Options, 16
- Power, 15
- Quality, 15
- Redial/Pause, 16
- Reduce/Enlarge, 16
- Scan, 15
- Select, 16
- Speed Dial, 16
- Stop/Clear, 15

C

- cards
 - loading, 26
- cartridges, ink
 - aligning, 65
 - installing, 63
 - removing, 64
- cartridges, print
 - replacing, 63
- Color (Start) button, 16
- copies, 59
- Copy (Select mode) button, 15
- copy settings, 57
- copying
 - operator panel, 33
 - software, 33
- custom size paper

- loading, 27, 31

D

- Dell All-In-One Center, 56
 - accessing, 56
- Dell Picture Studio
 - accessing, 62
 - using, 62
- Dell Printer Solution Center
 - accessing, 61
 - using, 61
- duplexing, 60

E

- envelopes
 - loading, 26
- envelopes printing, 59
- error messages
 - Ink Low, 78
 - Paper Jam, 78
 - Paper Out, 78

F

- Fax (Select mode) button, 15
- faxing, 40

G

- glossy paper
 - loading, 26
- greeting cards
 - loading, 26

I

- I Want To
 - change quality settings, 59
 - change speed settings, 59
 - print a banner, 59
 - print a photo, 59
 - print a poster, 59
 - print an envelope, 59
 - print on both sides of the paper, 59
 - see more printing ideas, 59

- index cards
 - loading, 26

- ink cartridges
 - aligning, 65
 - installing, 63
 - removing, 64
 - replacing, 63

- Ink Low message, 78

- installing ink cartridges, 63

- installing software, 81

- iron-on transfers
 - loading, 27
 - printing, 59

K

- keypad buttons, 16

L

- Lighter/Darker button, 16
- lights, blinking, 80
- loading
 - cards, 26
 - custom size paper, 27, 31
 - envelopes, 26
 - greeting cards, 26
 - index cards, 26
 - iron-on transfers, 27
 - photo cards, 26
 - photo paper, 26
 - postcards, 26
 - specialty paper, 31
 - transparencies, 26

M

- maintenance, 63
- media
 - loading, 31
 - specialty, 31
- messages, error
 - Ink Low, 78
 - Paper Jam, 78
 - Paper Out, 78
- multiple copies, 59

N

- Number of Copies button, 15

O

- operator panel, 17

- copying with, 33
- using, 17

- Options button, 16
- ordering supplies, 2
- orientation, selecting, 60

P

- paper
 - banner, 27
 - envelopes, 26
 - loading, 31
- paper exit tray, 10
- Paper Jam message, 78
- paper jam, clearing, 78
- Paper Out message, 78
- Paper Setup tab, 60
- paper support, 10
- paper type sensor, 23
- photo cards
 - loading, 26
- photo paper
 - loading, 26
- photos
 - printing, 59
- postcards
 - loading, 26
- posters, printing, 59
- Preview section
 - Print/Copy preview, 58
 - Scan preview, 58
- Print Layout tab, 60

Print Properties
 accessing, 59
 Options menu, 61
 Paper Setup tab, 60
 Print Layout tab, 60
 Quality/Copies tab, 59
 Save Settings menu, 61
 tabs, 59
 using, 59

print to fax, 50

printing
 banners, 59
 envelopes, 59
 photos, 59
 posters, 59

projects
 enlarging or reducing images or documents, 39
 scanning a photograph to e-mail, 38
 scanning multiple images, 37
 scanning multiple pages or images, 37

Q

Quality/Copies tab, 59

R

Redial/Pause button, 16
Reduce/Enlarge button, 16
removing ink cartridges, 64

S

safety information, 4
Save Settings menu, 61
Scan (Select mode) button, 15
scan settings, 57
scanner lock, 11
scanner support, 11
scanner unit, 11
scanning, 34
 software, 35
scanning multiple images, 37
Select button, 16
settings, saving for future use, 61
setup, 13
software, 56
 Dell All-In-One Center, 56
 Dell Printer Solution Center, 61
 Fax Setup Utility, 44
 reinstalling, 81
 removing, 81
 uninstalling, 81
specialty media
 cards, 26
 coated, 26
 custom size paper, 27, 31
 envelopes, 26
 glossy, 26
 greeting cards, 26
 index cards, 26
 iron-on transfers, 27
 loading, 31

photo cards, 26
photo paper, 26
postcards, 26
transparencies, 26

Speed Dial button, 16
Stop/Clear button, 15
supplies, ordering, 2

T

toner, ordering, 2
top cover, 10
transparencies
 loading, 26
troubleshooting
 cartridge carrier stalled, 80
 out of paper, 78
 paper jam, 78

U

uninstalling software, 81

W

warranty, 98

